

Features

- 400 – 900 nm spectral sensitivity
- 5 ps impulse response
- 10 ps trigger jitter
- Trigger external or command
- 5 to 50 ns analysis duration
- 1024 x 1024, 12-bit readout camera
- Controlled via Ethernet, Internet (Web page)
- Options: high resolution read out cooling camera



Applications

- Research involving pulsed laser
- High speed optical communication
- Picosecond Time interval Meter
- Measurement of electron bunch for Synchrotron
- Biology and Photochemistry

Description

The CBF500 is well suited for single shot analysis of ultra-fast optical phenomena with high dynamic. All settings and data transfer can be remote controlled via Ethernet (10/100Mb/s) or Internet (Web page from Internal Web server).

The architecture of CBF500 is modular allowing to change module to meet your specific needs and requirements

A power full control panel Web page provides a simple method to configure the settings, to control the state of the instrument, and to display or store acquired data.

CBF500 is a licensed product under CEA contract.

Application Example: Checking of 6 GHz, 900 nm wavelength "Comb Generator" connected to Marker Input. The following burst is recorded at 5ns sweep duration.



6 GHz burst raw data (Image 1024 X 1024)

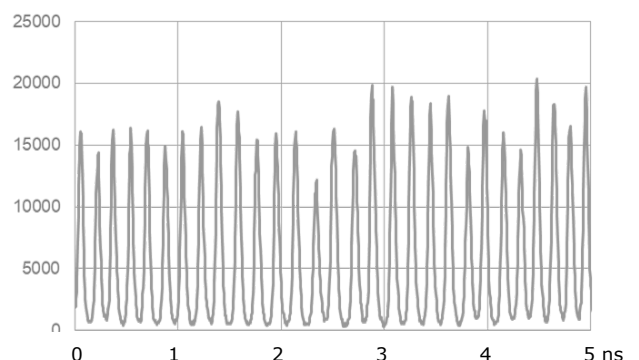

6 GHz burst Waveform (after profile processing)

CBF500

High resolution Streak Camera

Specifications

INPUT OPTICS MODULE	
Optical Signal Input	
Spectral transmission (UV)	400 nm - 900 nm
Image magnification ratio	1 : 1
Input Slit	200 μ m Width / 25 mm Length
Fiber Input for Marker	
Peak power	3 mW
Wavelength	680 nm
Connector	SMA 905
BASE MODULE (Electronics + Streak Tube)	
External Trigger	
Trigger level	0.5 V to 4 V
Sensitivity	5 V / 50 Ω
Jitter RMS	10 ps
Delay	100 ns
Maximum rate	1 Hz
Soft Trigger	
Trigger Source	Ethernet/ Internet command
Trigger output	
Function	Mark beginning of sweep
Level / rise time	5 V / 5ns under 50 Ω
Shape	Rectangular, 1 μ s width
RDY Output	
Function	Mark when the Readout Camera is ready
Level	5V under 50 Ω
Digitizing	
Sweep duration	5, 10, 20 and 50 ns
Impulse response	5 ps
Dynamic	150
Spatial magnification	1.3
Acquisition mode	Single shot, repetitive, static
Data format	Raw (image)
System control	
Setting and Data	Via Ethernet and Internet (Web pages)
Utility	
Power supply	24 V DC, 100 W
Operating temperature	+20 to 30°C
Dimension	400 mm (H), 370 mm (W), 605 mm (D)
Weight	21 kg
STANDARD READ OUT CAMERA MODULE	
Resolution	1024 X 1024 pixels, 12-bit A/D
Pixel size	24 μ m
Read noise	20e- RMS
Temperature cooling	15°C
Interface	Via the base module
OPTION 1: AC/DC POWER CONVERTER	
Input voltage	90 V to 240 V / 50 - 60 Hz
Output Power	24 V DC, 5 A
Dimensions	77 mm (H), 170 mm (w), 321 mm (D)
Weight	2 kg
OPTION 2: HIGH RESOLUTION READ OUT CAMERA MODULE	
Resolution	1392 X 1040 pixels, 16-bit A/D
Read noise	3e- RMS
Temperature cooling	Ambient to -50°C
Interface	USB to PC

CBF500

High resolution Streak Camera

Operating Information

Block diagram of the Streak Camera

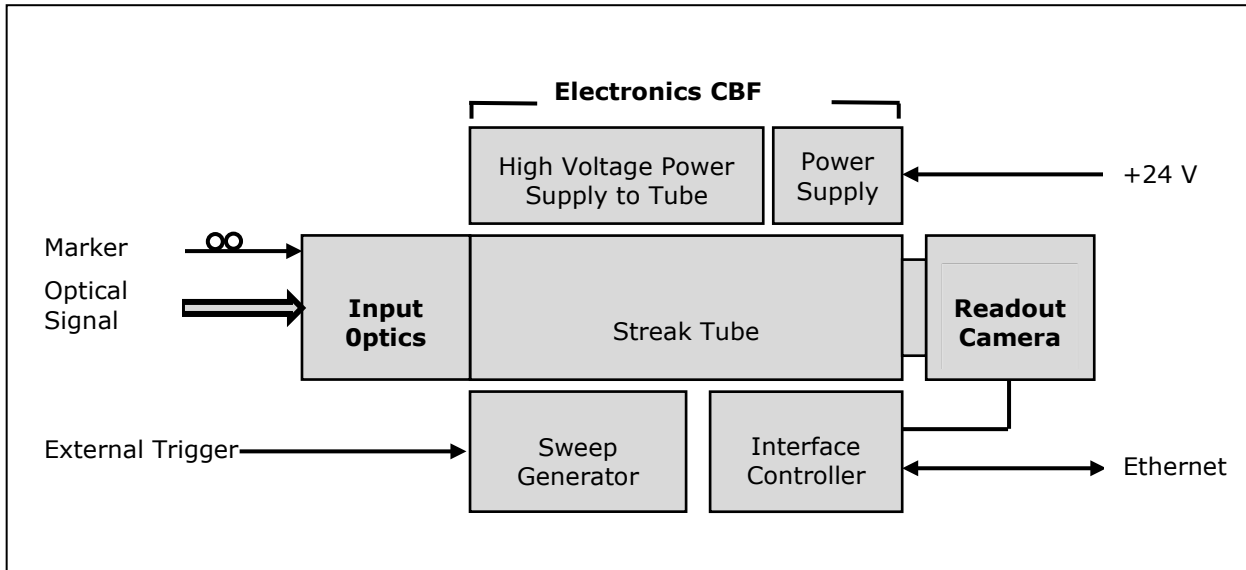

Input optics:

In this module the light is projected into a slit and focused on the photocathode of the streak tube. Marker Input is a specific channel to stamp the optical signal. In standard the Slit width is 200 μm . Other width are available (ask to the factory)

Streak tube

Streak tube is heart of the instrument. Photocathode converts the photon in a number of electrons proportional to the intensity of the light. These electrons are accelerated, swept and after which they are bombarded the phosphor screen to create an image. Photocathode is with multialkali on sapphire window (S20 type).

Sweep generator

The sweep generator can be triggered from an external signal or Ethernet/ internet command. The sweep speed is adjustable from 5 ns, 10 ns, 20 ns and 50 ns. To optimize performance each sweep as a specific settings saved in the instrument.

High Voltage Power Supply

Three High Voltage programmable Power Supplies are connected to Cathode, Grid and Focus electrodes of the Streak tube. From a Voltage fault a high performance safety system stop the three High Voltage Power Supplies to avoid any damage on Streak tube.

Readout Camera

A digitizing system is coupling to the screen tube via fiber optics to readout the image. This system enable precise digital acquisition stored in image memory (Raw data). The Raw data can be processed and transferred via Ethernet to provide a two dimensional waveform data. In option a high resolution read out camera can be connected.

Interface Controller

It manages internal functions and user interfaces. All the parameters and data can be remote controlled via Ethernet (10/100 Mb/s) or Internet (Web page from internal Web server) All parameters values are automatically saved.

CBF500

High resolution Streak Camera

Control and Software Tools

They are two ways to control the Streak Camera:

- **"Quick remote mode"** via Internet and web pages. Web page from embedded server, provides a simple method to configure setting, to control operation, to display status of the instrument and to display the raw data stored in readout camera. Data can be saved via Ethernet in "RAW" data file format for off-line analysis or in "JPEG" file format to be displayed.

The web page can be opened via internet explorer, Mozilla Firefox or Chrome.

After connecting a cable from the CBF500's Ethernet port to your computer network, enter the CBF500's IP address into your PC's browser (the IP address can be identified or assigned via the web page). The browser will automatically open the control panel web page on your PC.

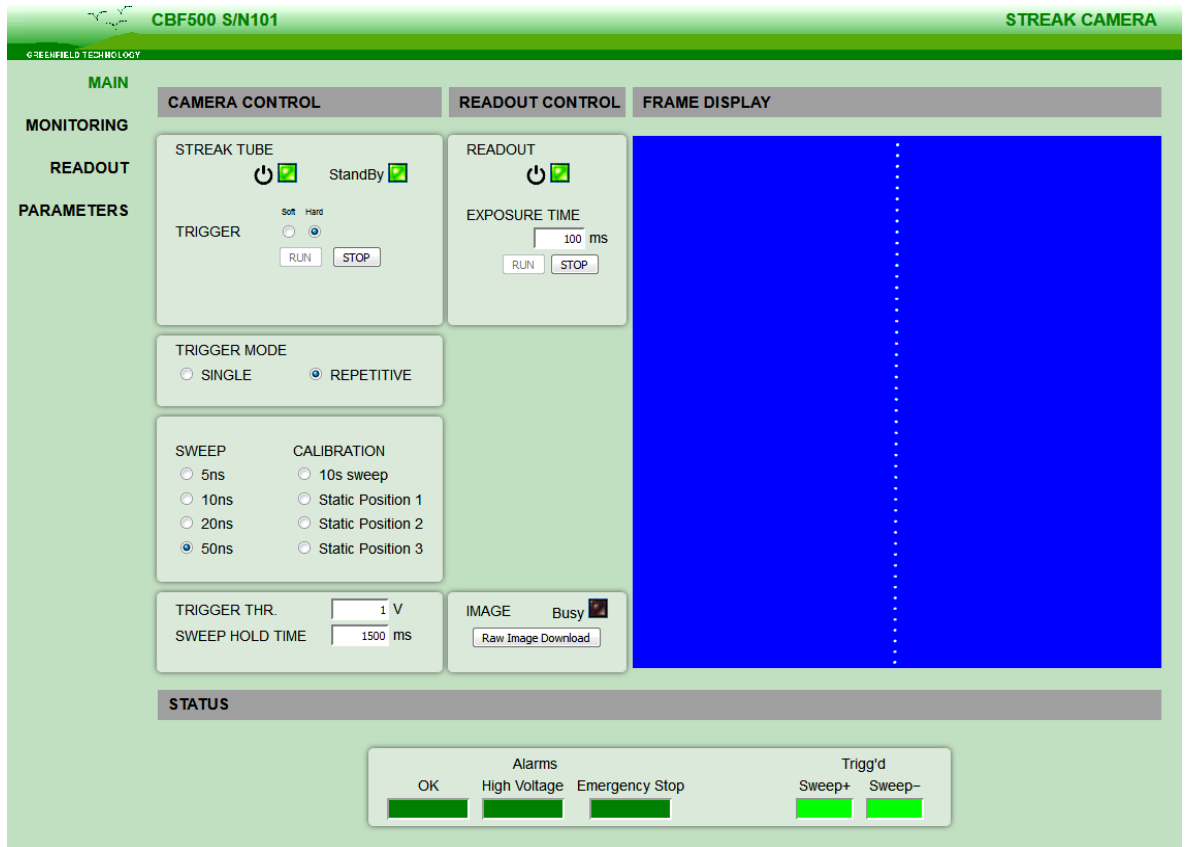

Main Web page

- **"General remote mode"** via Ethernet and LabVIEW software application or other PC software application. (Example of use is provided in a user's manual)

CBF500 High resolution Streak Camera

Inputs outputs Interfaces

Enclosure (dimension are in mm)

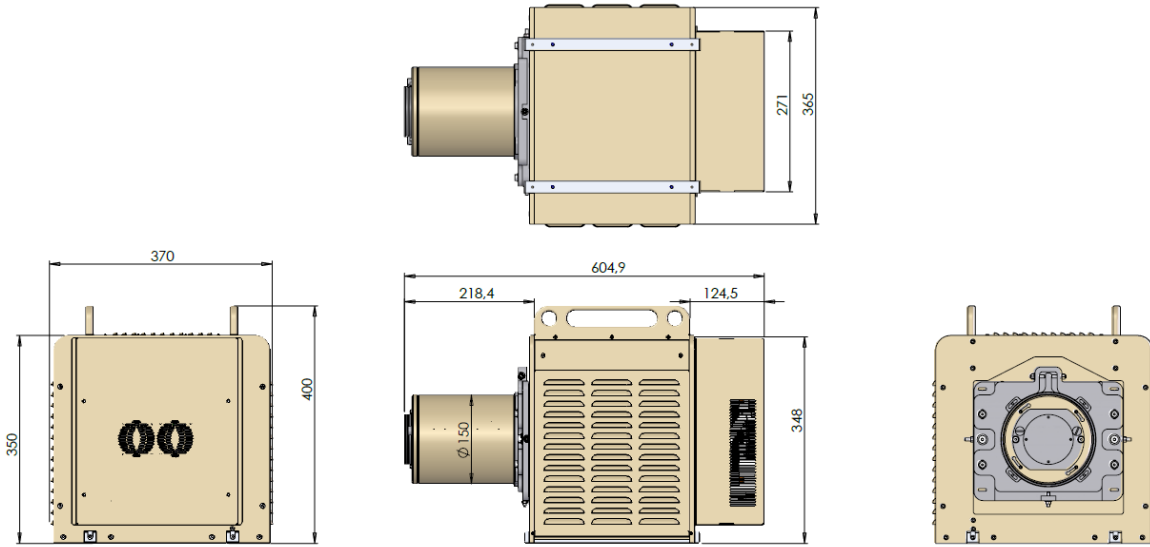

Right Panel Input and output

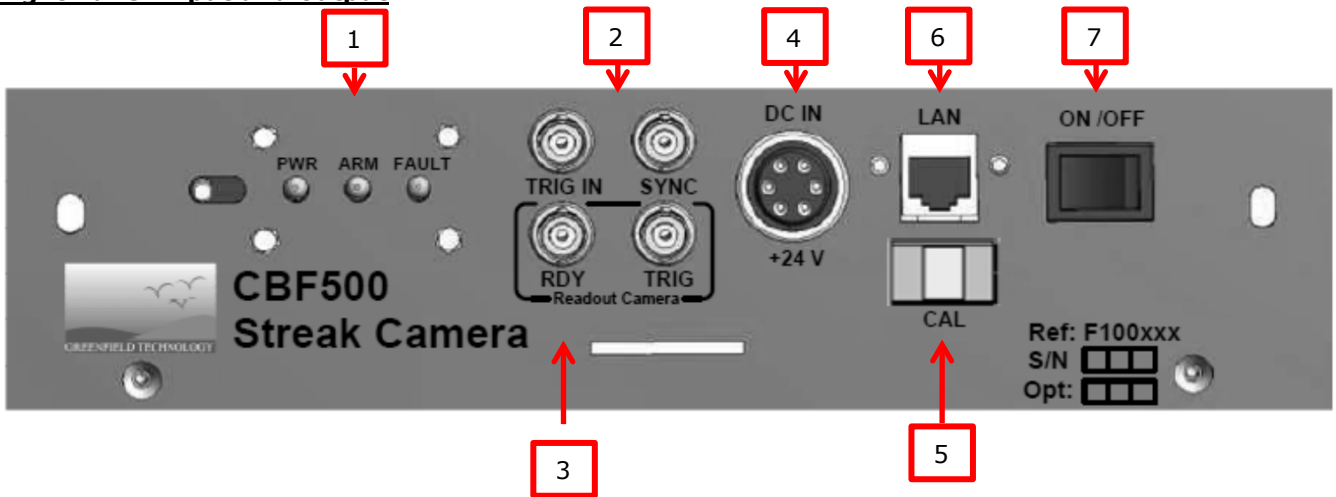

Connectors, Switch and Indicators

Right Panel					
Indicators			Readout Camera connectors		
1	PWR	Power On	3	TRIG	Trigger Input : BNC connectors
	ARM	Trigger Armed		RDY	End of cycle : BNC connector
	FAULT	Error	Interface Connectors and Switch		
Trigger connectors			4	DC IN	+24 V Power input: UTO Souriau connector
2	TRIG IN	Trigger Input: BNC connector	5	CAL	N.C
	SYNC	Trigger Output: BNC connector	6	LAN	Ethernet connection: RJ45 connector
			7	ON/OFF	Power Switch On/off

Ordering Information

Model	Description
CBF500	Base version with standard readout module
CBF500-1	Adds option 1: AC/DC power converter
CBF500-2	Adds option 2 : High resolution readout module