

7 GHz Transient Digitizer

Features

- 7 GHz bandwidth with slow roll off
- 50 ps rise time
- Up to 1800 GS/s sampling rate
- 13-bit vertical resolution
- 2000 V maximum input voltage without overload
- Controlled via front panel and Ethernet
- 19" Rack, 4U, 560 mm
- Fiducial input for time stamping

Applications

- Diagnostics for Laser research and High-Energy physics
- Recording of fast single shot pulses
- EMC/EMP simulators
- High-voltage breakdowns
- Test of high speed circuits
- Automatic Test Equipment (ATE)



Easy remote control from standard browser in your PC

Description

Greenfield Technology's FTD10000 Fast Transient Digitizer is the fastest digitizer in the industry, specifically designed to record very fast single short pulses down to 50 ps with 13-bit amplitude resolution. It features unique performances such as a 7 GHz bandwidth with slow roll off giving a very good impulse response, a maximum input voltage of 2000 Volts without overload and a low noise giving a FS/N ratio >3000 (>70 dB).

The **new revision** adds new feature and improve the performance of the instrument. The new revision includes:

- An improved readout camera with 1800 x 1800 pixels resolution, 12-bit A/D and a cooling system
- An improved digitizing resolution by 78% (now up to 1800 GS/s on 1 ns duration... or 36 GS/s on 50 ns duration or...)
- Outstanding precision waveform processing
- An internal web server to control the instrument and analyze the sampling results, via a standard web-browser providing cursor and zoom capabilities
- Enhanced Ethernet speed up to 1000 Mb/s

Additional features include an input for timing fiducials and a large front panel display for easy and precise viewing. The panel's GUI allows for local and remote-control over-all setup and digitizing features as well as and viewing of results. As such the FTD10000 is an excellent solution for laboratory and automatic test application. The FTD10000 is a licensed product developed under CEA (Commissariat à l'Energie Atomique) contract.

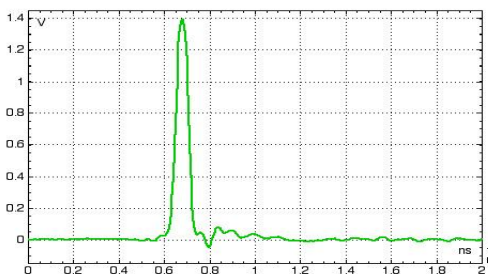

*50 ps impulse response (0.2 ns/div)
Generator is PSPL 4015B pulser*

7 GHz Transient Digitizer

Specifications

Signal Input										
Sensitivity	4.5 V into 50 Ω must be externally terminated									
Bandwidth	DC to 7 GHz (4 dB)									
Rise time	50 ps									
Input impedance	50 Ω									
Vertical position	+50 % to -50 %									
Maximum input	2000 V (at FWHM = 1 μ s)									
External Trigger										
Input impedance	50 Ω (internal)									
Signal polarity	Positive or negative									
Signal duration	>0.5 ns									
Trigger level	0.5 V to 4 V									
Maximum input	500 V (at FWHM = 1 μ s)									
Jitter RMS	5 ps									
Internal delay	40 + (10 ⁻¹ X analysis duration) to 540 ns									
Soft Trigger										
Trigger Source	Ethernet/ Internet command									
Trigger output										
Function	Mark beginning of sweep									
Level / rise time	10 V / 5 ns into 50 Ω									
Shape	Impulse wave, with FWHM >100 ns									
Digitizing										
Analysis sweep duration (ns)	1	2	5	10	20	50	100	2000	
Sampling rate (GS/s)	1800	900	360	180	90	36	18	0.9	
Horizontal resolution	1800 samples									
Vertical resolution	13-bit									
Non-volatile memory	1 record & settings									
Full Scale /Noise Ratio	3000 (70 dB) at 10 ns Analysis sweep duration									
Acquisition mode	Single acquisition or repetitive acquisitions at max rate of 0,7 Hz (TBC) or electrical zero									
Waveform processing	Raw data (image) Fast (waveform) High (corrected waveform) Very High precision (corrected waveform) with PC software application.									
System control										
Command and Setting	Via Ethernet and Internet (Web pages)									
Data transfer	Via Ethernet (10/100/1000 Mb/s)									
LEDs	For viewing instrument status									
Local viewing and control	With 8"2 LCD display, keyboard and knob									
Software	LabView application for Windows 10									
Fiducial input										
Function	SMA connector provides a marker synchronous of recorded signal. The fiducial input signal is added to the signal input.									
Sensitivity	0 to 3 V amplitude adds 10% of FS									
Bandwidth	0.1 MHz to 3 GHz									
Impedance	40 Ω									

7 GHz Transient Digitizer

Specifications (cont'd)

Inputs /outputs (all are located at rear of the equipment)	
Signal input and output	N connectors
Trigger input	BNC connector
Trigger output	BNC connector
Fiducial input	SMA connector
Ethernet port	RJ-45
Environment	
Operating temperature	10 to 30°C
Humidity	85% non-condensed at 40°C
Power supply	
Voltage	90 to 240 VAC
Power consumption	100 W
Physical characteristics	
Dimensions	Width = 19 inch Height = 173 mm (4 U) Depth = 560 mm (670 mm with handles)
Weight	20 kg

Dynamic performance

The average bandwidth curve is the following

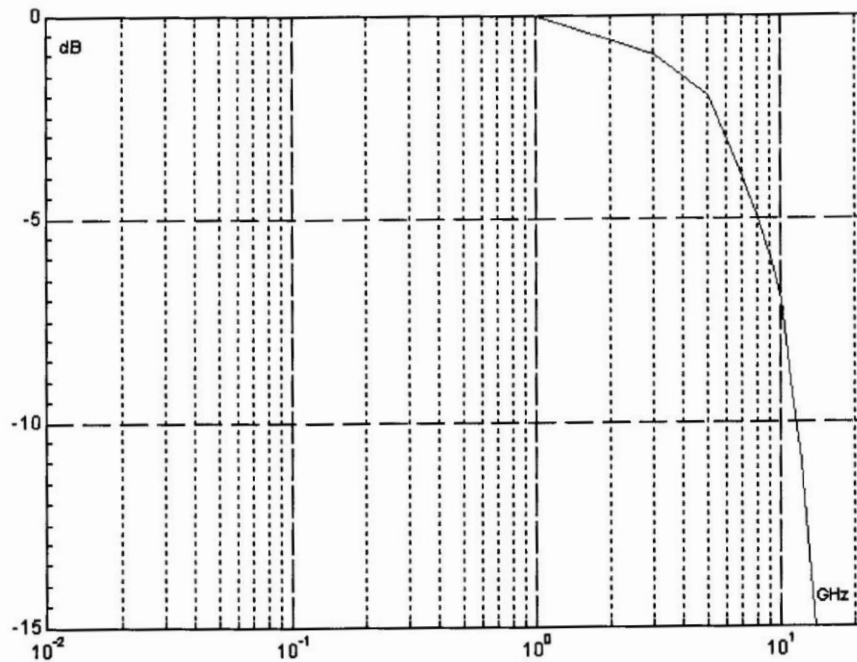

7 GHz Transient Digitizer

Functional overview

Block diagram

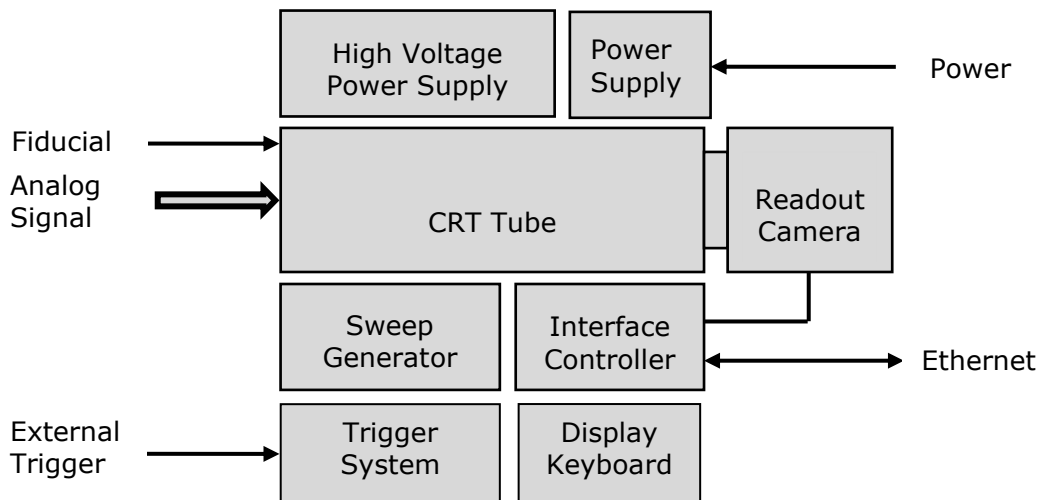

Block diagram

Operating principle: The heart of the digitizer is a very large bandwidth Cathode Ray Tube (CRT) directly coupled to a CCD camera through two fiber windows.

The FTD10000 uses a scan conversion principle (fast in, slow out).

Phase 1: The digitizer records the signal in a fast analog memory (screen of the CRT).

Phase 2: The readout camera captures the fast memory slowly and digitizes it in order to store it in a video memory.

The signal is extracted from the video memory through image processing and defect correction. The acquired waveform can be viewed on local display and read via the LAN interface and exported to standard signal analysis tools.

Trigger system

A rear panel BNC connector allows an external trigger for synchronization. Delay of the trigger can be adjusted from 40 ns to 240 ns for adjusting the record time to the signal.

Sweep generator

The sweep generator can be triggered from an external signal or Ethernet/ internet command. The sweep speed is adjustable from 1 ns to 2000 ns. To optimize performance each sweep has a specific set saved in the instrument.

High Voltage Power Supply

Three programmable High Voltage Power Supplies are connected to Cathode, Grid and Focus electrodes of the CRT tube. In case of Voltage fault a high-performance safety system stops the three High Voltage Power Supplies to avoid any damage on the CRT tube.

Interface Controller

It manages internal functions and user interfaces. Main internal function is Acquisition mode started by pressed ARM key (or RUN)

- **Single Mode:** The instrument acquires single waveform then process and displays it locally
- **Repetitive mode:** The instrument continuously acquires a waveform then process and display subsequent waveform on local display until the mode is stopped by pressed ARM key (or STOP).

All the parameters and data can be locally controlled or remotely controlled via Ethernet (10/100/1000 Mb/s). All parameters' values are automatically saved.

7 GHz Transient Digitizer

Control and software tools

Local mode

The FTD10000 can be locally controlled via GUI on the local screen, keyboard, and knob. The GUI is constituted of two parts.

- Left part to display the different record.
- Right part to select the settings and run the records

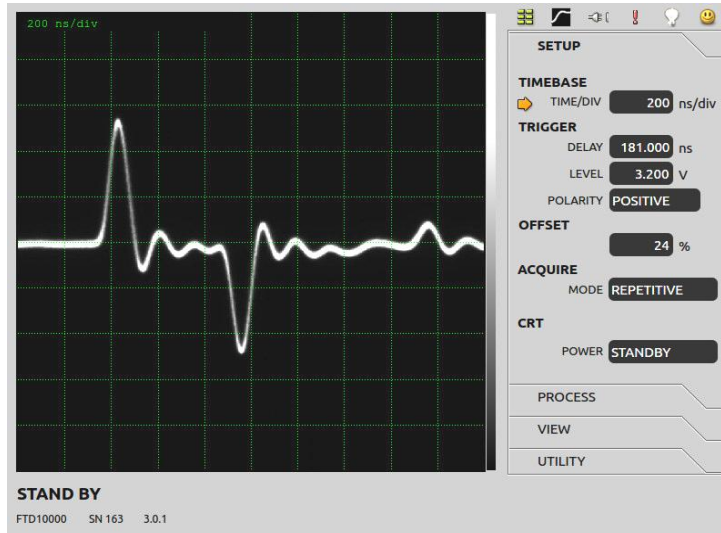

Local GUI

Easy remote way via Ethernet and remote-control GUI (see below). GUI page from embedded server, and standard browser (Edge, Firefox or chrome) in your PC, provides an easy and quick method to configure settings (Trigger, offset... processing) to control operation, to display data recorded and to save data for off-line analysis. With remote control GUI, the FTD10000 operates as a desktop oscilloscope but the user can be far from the instrument and takes advantage of all PC tools (large screen...standard software)

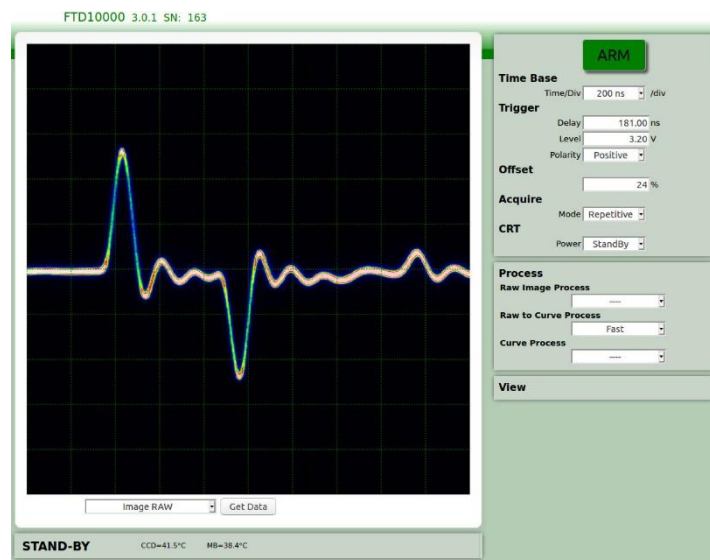

Remote GUI

General remote way via labView application or other PC software application (see example in user' manual)

7 GHz Transient Digitizer

Product Interface

Front Panel

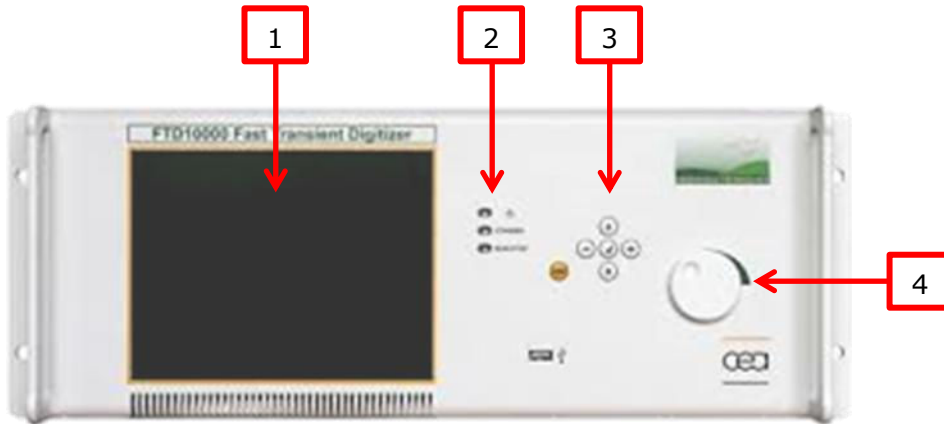

Rear Panel

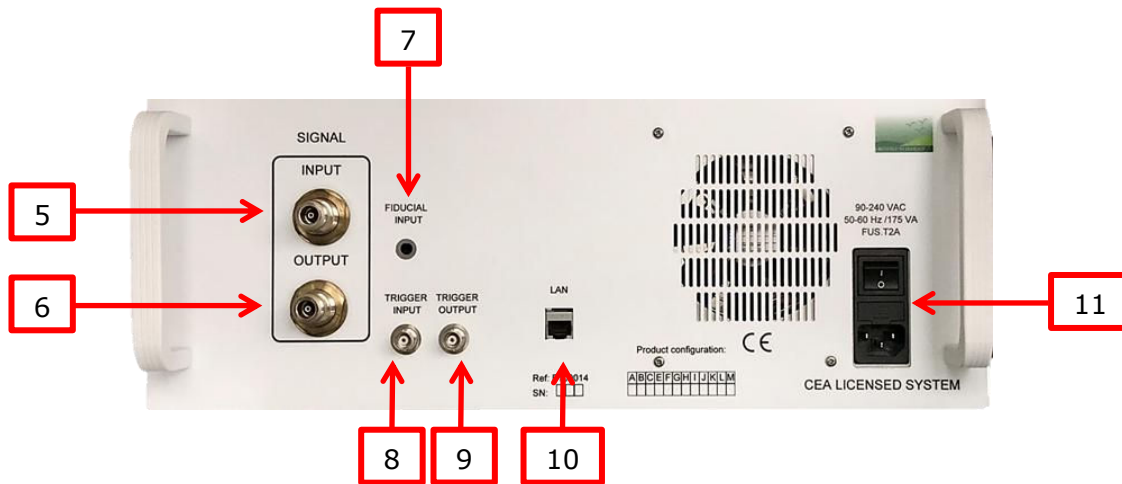

Interface

Front panel		Rear panel	
Indicators		Connectors	
1	Display for local mode	5	Input for analog signal: N connector
2	Indicators for viewing instrument status O: Indicates power supply is on STAND BY: Indicates CRT power is off RUN/STOP: Indicates instrument is armed	6	Output for 50 Ω load: N connector
		7	Fiducial input: SMA connector
		8	Trigger input: BNC connector
		9	Trigger output: BNC connector
3	Keyboard for local mode	10	Ethernet network: RJ45 connector
4	Knob for local mode	Switch	
		11	Power on/off switch and plug

Ordering information

Model	Description
FTD10000	Base version

Digitizer part number is: FTD10000