

Features

- Four Independent Delay Channels (up to ten in option)
 - 1 ps Time Resolution
 - <10 ps Jitter for Internal Triggered Delays
 - <25 ps Jitter for External Triggered Delays
- Adjustable Output Pulse up to 10 V, 1 ns Rise Time
- External or Internal Trigger Sources for Every Channel
- Internal or External Clocking up to 90 MHz
- Independent Control of Delay, Width, and Amplitude
- Controlled via Ethernet, Web Page and Front Panel
- Compact Packaging 1U, 19"
- Options:
 - Extension to 8 or 10 Channels
 - Output pulse: TTL, 20 V, 32 V, or Optical

Applications

- Components Test
- Automated Test Equipment (ATE)
- System Laser Timing Control
- Control Flash Lamps and Q-switches
- Synchronization with selectable clock frequency - Mode Locked Laser
- Precision Pulse Application
- Gate High-Speed Cameras
- Instrument Triggering



Description

The GFT1004 Digital Delay Generator provides four independently delayed pulses on the rear panel with options for eight or ten channels. Delays up to 10 seconds can be programmed with 1 ps resolution, and channel-to-channel jitter is less than 10 ps RMS. BNC outputs deliver up to 10 V, 1 ns under 50 Ω. Pulse amplitude and width are adjustable on each output channel.

One input channel, or two internal synchronized timers are used to trigger all output channels. One T0 channel is used as a time reference for all of the delayed output pulses.

The GFT1004 is a Digital Delay Generator that operates either as a standalone device, or as a component in a timing system (Option 2). In a timing system (see below), the GFT1004 is operated in conjunction with a GFT3001 Master Transmitter that controls and synchronizes a number of GFT1004 DDGs via optical fibers.

GFT1004 parameters can be locally controlled over the front panel keys and LCD display, and remotely controlled via Ethernet (10/100 Mb/s) or Internet (web page from internal web server).

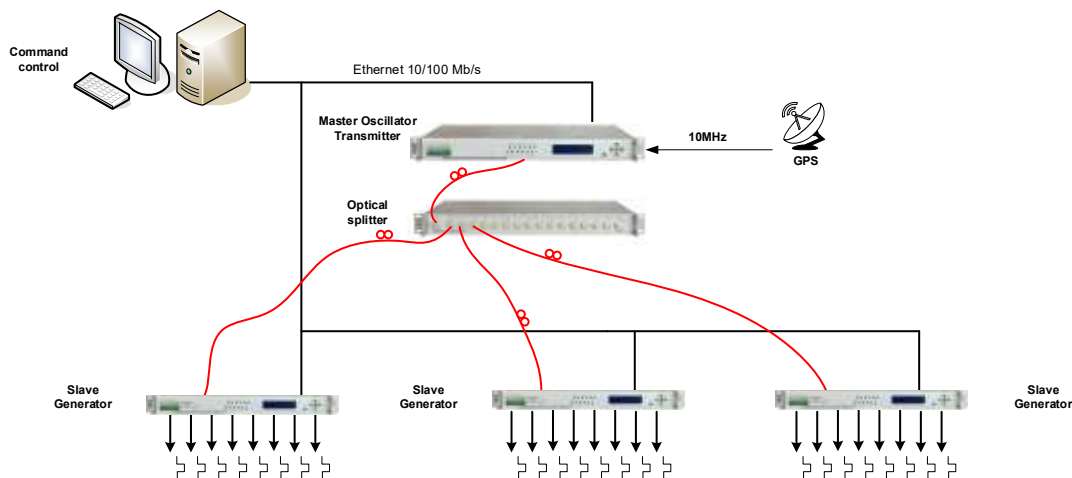

Timing System Application with 3 Slave Generators (24 delay Channels)

Specifications

Delay Channel	
Number	4 independent
Range	0 to 10 seconds
Resolution	1 ps
RMS Jitter	< 10 ps + delay x 10 ⁻⁷ (channel-to-channel in internal trigger) < 25 ps + delay x 10 ⁻⁷ (external trigger to any channel) < 10 ps + delay x 10 ⁻⁷ (external time reference to any channel)
Accuracy	< 150 ps + delay x 10 ⁻⁷
Time Base	155.52 MHz frequency, 0.5 ppm stability
External Trigger Input	
Repetition Rate	Up to 100 kHz or single-shot
Trigger Level	+1 V / 50 Ω
Slope	Positive
Minimum Trigger Delay	< 100 ns (insertion delay)
Connector	BNC
Internal Trigger	
Two Synchronized Timers	Frequency = 1 Hz to 100 kHz, resolution = 6.43 ns
Output Pulse T0	
Amplitude / Width	2.5 to 10 V / 100 ns to 10 ms under 50 Ω
Output Pulse T1 to T4	
Amplitude	2.5 V to 10 V in steps of 10 mV
Load	50 Ω
Rise/Fall Time	< 1 ns / 3 ns
Width	100 ns to 10 ms in steps of 6.43 ns
Connector	BNC
External Time Reference	
Threshold	0 V, internal 50 Ω
Level	Min -3 dBm, typical 0 dBm
Frequency	10 MHz (other frequencies are available up to 90 MHz)
Inhibition	
Input	Active high, Threshold = 1.5 V, Repetition rate < 100 kHz
Command	Each trigger Channel can be Inhibited
General	
Software	Free Drivers for Windows 7 / 10, VI LabView driver
User Interface	Front panel, Ethernet 10/100 Mb/s, Internet (web page)
Power Consumption	90 to 240 V / 50 - 60 Hz/ 0.25 A
Weight / Size	< 5 kg / 19" W X 363 mm D X 1U H
Options	
Option 1:	Extension to 8 channels
Option 2:	Optical input for timing system mode
Option 3:	Clock output (sine wave, 3 dBm, -40 dBm spectral purity, 77.76 MHz frequency, 5 ps RMS jitter to any channel)
Option 4:	32 V channel output (Width = 1 μs, rise/fall time = 3/15 ns under 50 Ω)
Option 5:	Extension to 10 channels
Option 6:	5 V to 20 V channel output (Width = 0.1 to 10 μs, rise/fall time = 3/15 ns under 50 Ω)
Option 7:	TTL level (2.5 to 6 V) channel output (Width=100 ns to 10 s, rise/fall time = 5/15 ns under 50 Ω, positive or negative pulse)
Option 8:	Optical channel output >250 μW (wavelength = 850 nm, width = 0.1 to 10 μs, rise/fall time = 1/2 ns, ST connector)
Option 9:	100 ps delay channel resolution

Functional Overview

Block Diagram: The GFT1004 includes the five following functions: Time Base, Trigger Controller, Digital Delay Channel, Channel Output and Interface Controller.

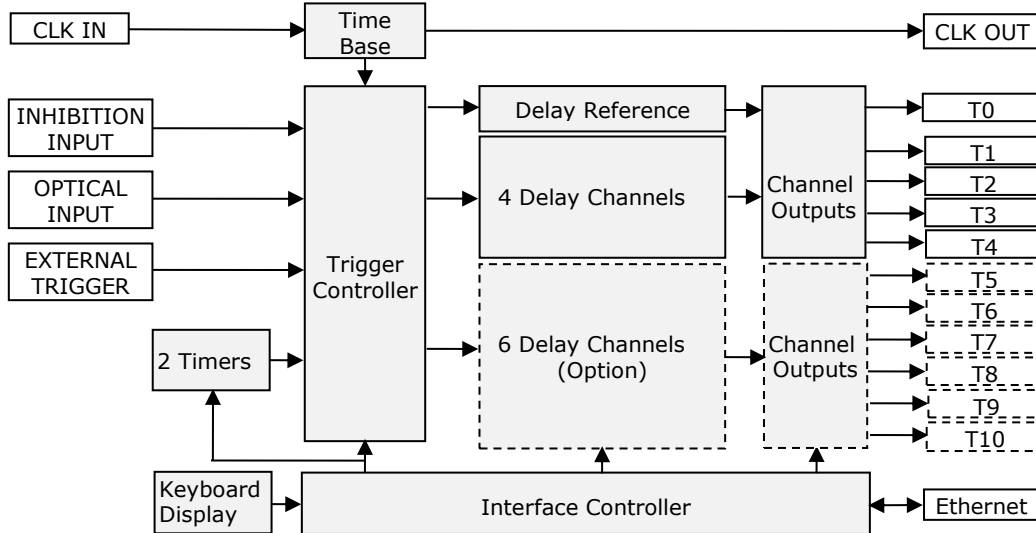

Block diagram of the delay generator

Time Base: This function provides a 155.52 MHz time base from an internal reference or an external 10 MHz reference. As an option, the external reference can be up to 90 MHz (Ask to factory).

Trigger Controller:

This function provides 4 trigger sources to each delay channel

- External trigger source: When the external trigger source is selected, a rising edge on "TRIG IN" starts a delay sequence. After each channel's delay period, a pulse appears on each channel's output
- There are two internal trigger sources from two synchronous Timers. The frequency of each Timer is programmable from 1 Hz to 100 kHz
- Optical trigger source (as an option) is operated in conjunction with a GFT3001 Master Transmitter that controls a number of GFT1004. Via optical fiber, the GFT3001 provides a serial data stream for time base synchronization, single-shot, repetitive triggers, and inhibition information to the multiple GFT1004 units at distance greater than 1 km from the GFT3001 Master Transmitter.

"Inhibition input" allows the system to quickly inhibit selected outputs.

Delay Channel: They are 4 independent delay channels (with options for eight or ten channels). The delay from the selected trigger source is programmable up to 10 seconds in 1 ps increments.

"T0" output channel is used as a time reference (delay = 0) for all delayed output pulses.

Channel Output: Each delayed output pulse (T1 to T10) can be independently adjusted in level and width. The outputs are designed to drive a 50 Ω load.

As an option, channel output level can be 2.5 to 6 V, or 5 to 20 V, or fixed 32 V, or optical pulse.

Interface Controller: It manages internal functions and user interfaces. The parameters can be locally controlled over the front panel keys, and remotely controlled via Ethernet (10/100 Mb/s) or Internet (web page from internal web server) All parameter values are automatically saved.

Example of channel output mode

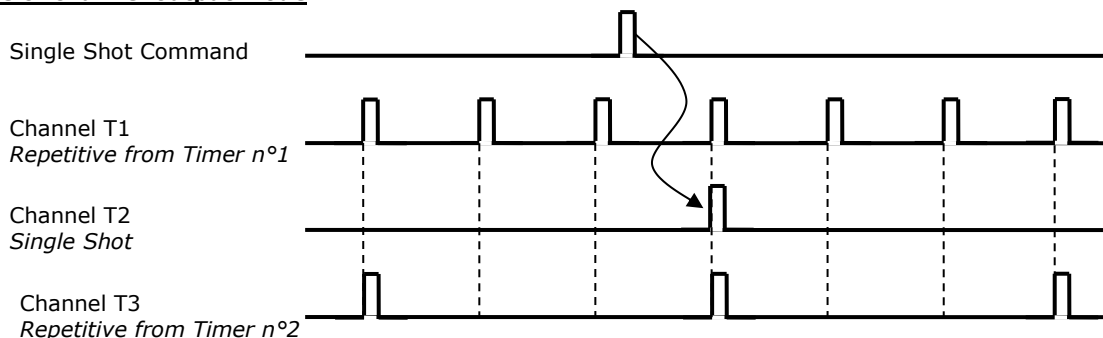

Control and Software Tools

They are three ways to control the generator:

- **"local way"** via the front Panel Display an Key board

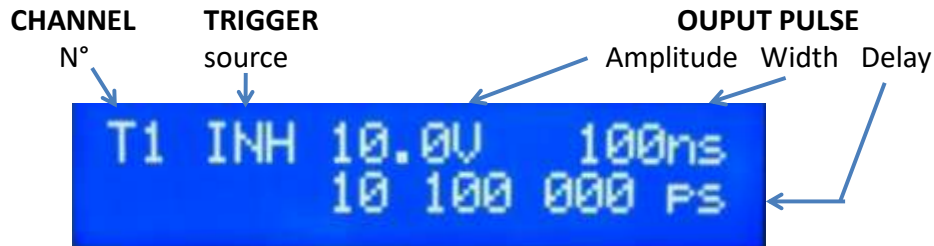

Display example: Settings of Channel T1

- **"Quick remote way"** via Internet and control panel web pages.
 Web page, from embedded Web server, provides a simple method to configure settings for each channel (delay, output amplitude, polarity, output width, trigger mode, trigger source), to control operation and to display the status of the instrument.
 The configuration information of the instrument is stored and saved in the GFT1004.
 The web page can be opened via Internet Explorer, Mozilla Firefox or Chrome.
 After connecting a cable from the GFT1004's Ethernet port to your computer network, enter the GFT1004's IP address into your PC's browser (the IP address can be identified or assigned via the front panel). The browser will automatically open the control panel web page on your PC.



Setup Web page

- **"General remote way"** via LabVIEW software application or other PC software application.

Front and Rear Panel

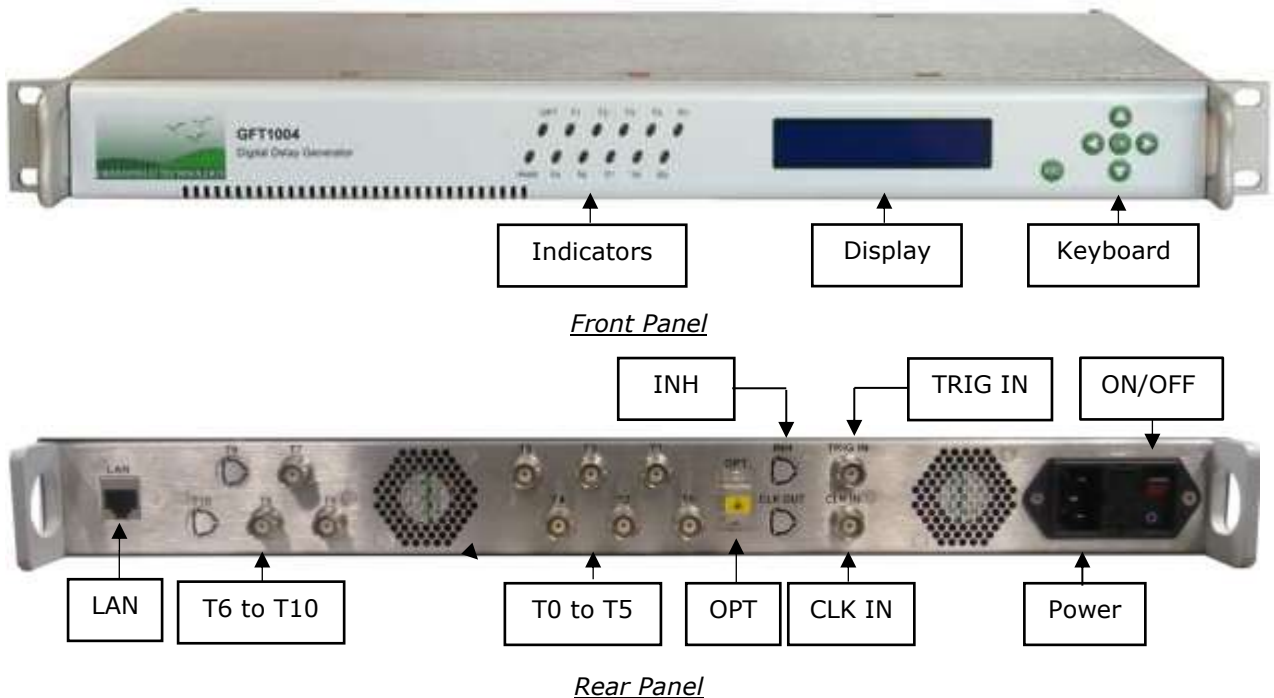

Connector, Switch, Indicators

Front Panel		Rear Panel	
• Indicators		• Connector	
OPT	Synchronized by optical network	LAN	LAN connection: RJ45 connector
T1	Blinks at the trigger frequency of channel 1	OPT	Optical input: SC/PC connector
T2	Blinks at the trigger frequency of channel 2	CLK IN	Clock input: BNC connector
T3	Blinks at the trigger frequency of channel 3	CLK OUT	Clock output: BNC connector
T4	Blinks at the trigger frequency of channel 4	T0	T0 output: BNC connector
T5	Blinks at the trigger frequency of channel 5	T1 to T10	T1 to T10 output pulses: BNC connector
PWR	Power supply ON	TRIG IN	External Trigger Input: BNC connector
T6	Blinks at the trigger frequency of channel 6	INH	Inhibition input: BNC connector
T7	Blinks at the trigger frequency of channel 7	Power	AC power plug (90-240 V)
T8	Blinks at the trigger frequency of channel 8	• Switch	
T9	Blinks at the trigger frequency of channel 9	ON/OFF	Power ON/OFF switch
T10	Blinks at the trigger frequency of channel 10		
• Small keyboard for local control			
• Display for local control			

Ordering information

GFT1004 Delay Generator part numbering

GFT1004-X-X-X-X (Where "X" is option number)

Ordering examples

GFT1004-1-2 (GFT1004 with extension to 8 channels and optical input for timing system mode)

GFT1004-5-7-3 (GFT1004 with extension to 10 channels, TTL level channel output, and clock output)