

4 Channel Programmable Delay Module

Features

- Four independent delay channel
- Programmable delay in 0.5 ps increments
- 7 ns delay range
- <3 ps input to output RMS jitter
- Up to 50 MHz channel rate
- LVPECL / CML / LVDS channel input
- LVPECL channel output with MUX mode
- Delay control via SPI link
- Operate from DC +5 V
- Compact module: 40 X 25 mm
- Option: Evaluation board with TTL outputs

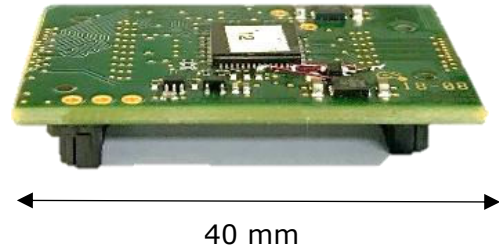

Applications

- Components Test
- OEM Application
- Data de-skewing
- Timing adjustment

Description

The GFT144 module is a Four Channel Programmable Delay module designed for component test, data de-skewing and timing adjustment. This compact module is well suited for OEM application with an interface via 2 standard connectors, a small size and only one power source.

The core of the module is made with a component (QFN 56 pins) specially designed by Greenfield Technology.

The required delay is accomplished by programming each delay channel via Serial Data Interface. The delay as an increment resolution of typical 0.5 ps in the programmable delay range of 7 ns per channel.

The channel input can be driven directly by differential LVPECL / CML or LVDS logic levels. The output is compatible with DC or AC LVPECL.

Typical GFT144 application (see below) would be to control from FPGA application the four timing of a device with high rate and very high resolution.

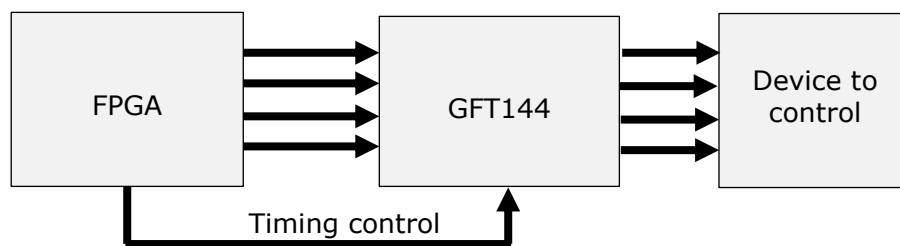

Typical application

4 Channel Programmable Delay Module

Specifications

Delay Channel	
Number	4
Range	7 ns @ 150 MHz (or 5 ns @ 200 MHz) clock input
Resolution	0.5 ps typical
Linearity	±50 ps maximum (without correction)
Jitter RMS	3 ps (input to output)
Channel Input	
Level	LVPECL / CML / LVDS
Minimum width	10 ns
Maximum width	Up to 1 s
Connector	Samtec
Channel Output	
Level	LVPECL
Rate	DC to 50 MHz
External Load	50/50 Ω and 50 Ω (see page 3)
Rise Time	750 ps
Fall Time	750 ps
Insertion Delay	< 5 ns (input to output)
Mux mode	1 to other channel outputs
Connector	Samtec
Clock input	
Level	LVPECL
Frequency	150 MHz to 200 MHz
General specifications	
Control	SPI, Serial data interface
Size	40.0 x 25.0 x 10.0 mm
Power V/A	+5 V / 200 mA max.
Power connector	Samtec
Option : Evaluation board	
Outputs	TTL level (adjustable 1.5 to 5 V under 50 Ω)
Trigger mode	Internal (from programmable timers) or external
Interface control	USB to UART
Software tool	The board is supplied with window software application which include a front panel graphical interface.
Power Adapter	External AC (90 -240 V) to DC (+ 5 V) adapter furnished

4 Channel Programmable Delay Module

Functional overview

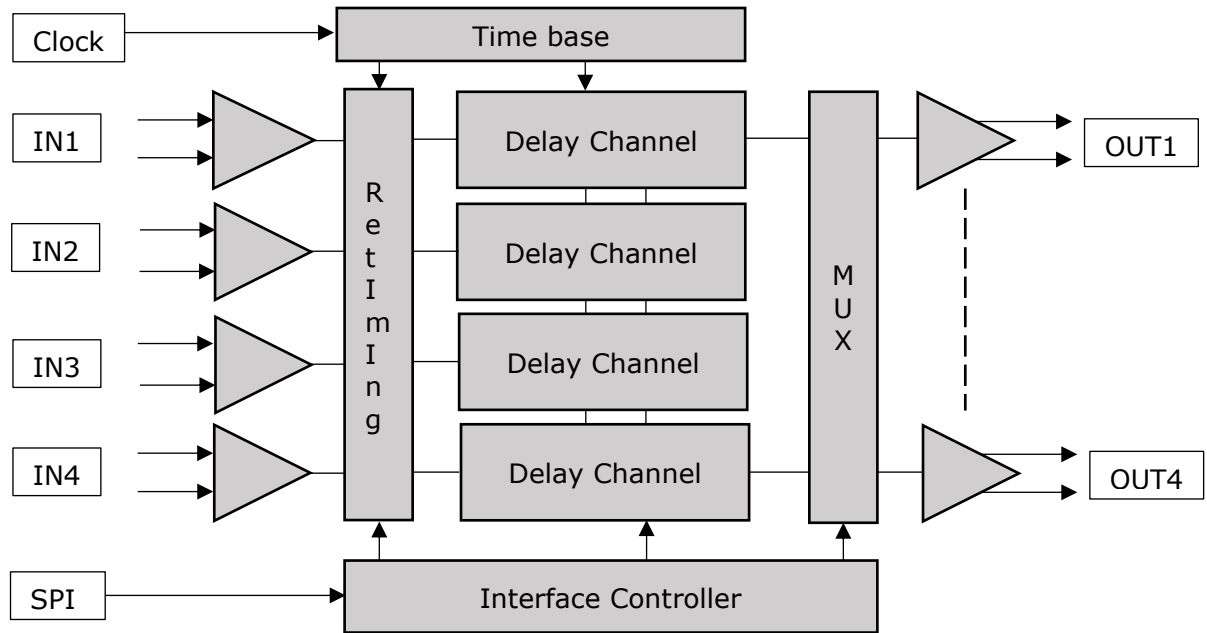

Block diagram

Time base: This function provides time base from external reference (Clock) to synchronize all the functions.

Retiming: Allows to synchronize all the "IN" input signal with clock. This function can be inhibited.

Delay Channel: They are 4 independent delay channels. The delay is programmable in 0.5 ps increment. With **Mux** function each delayed output can be AND' to other inverted outputs.

Channel Output: Level of the output is LVPECL and must be loaded as showing below.

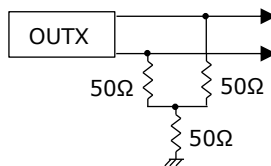

Interface Controller: it manages internal functions and user interface. All the parameters can be controlled via SPI (serial data interface).

Timing principle

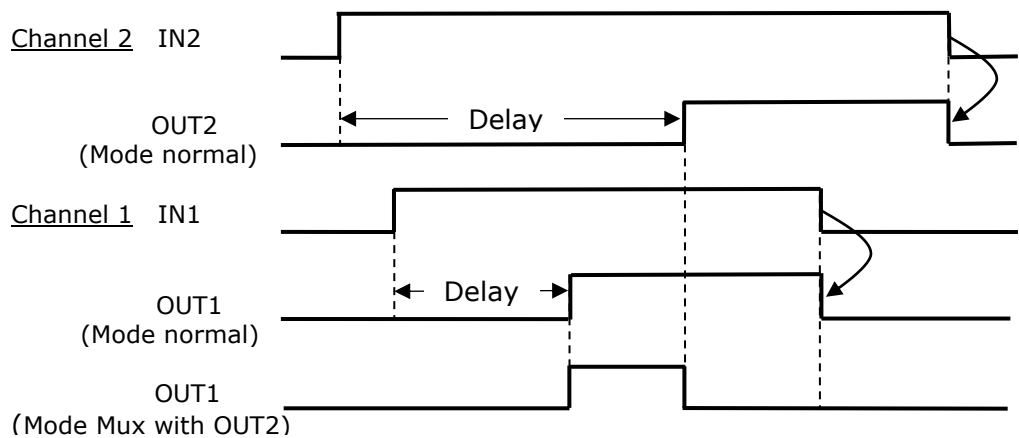

4 Channel Programmable Delay Module

Product Interface

Top view (size x2)

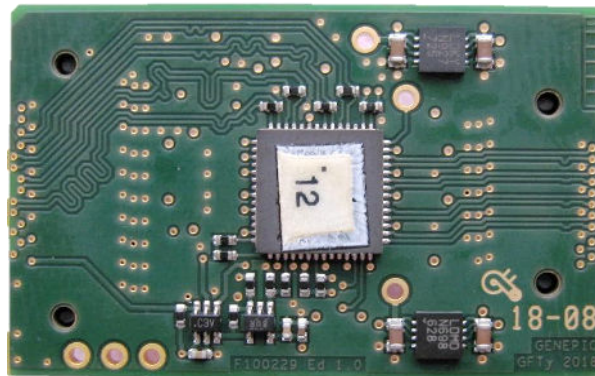

Bottom view (size x2)

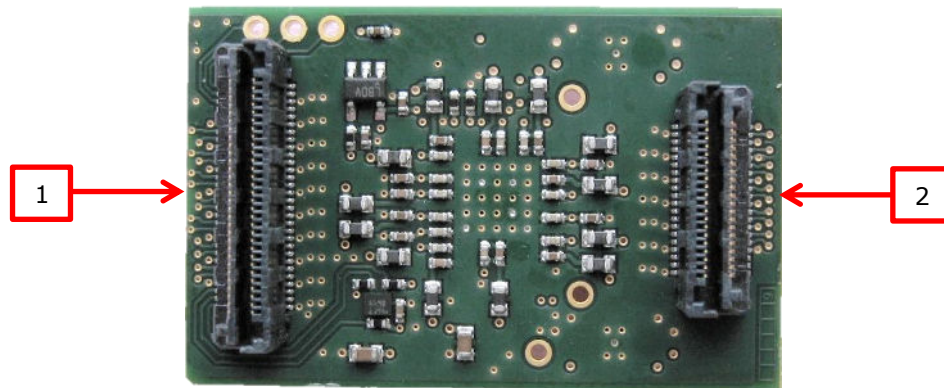

Interface

Bottom View	
1	Channel Inputs, Clock, SPI interface: Samtec 2 X 20 pin connector
2	Channel Outputs, +5V power: Samtec 2 x 10 pin connector

Ordering information

Part number	Description
GFT144	4 channel programmable Delay Module Base version
GFT144-01	GFT144 with evaluation board

Ordering example: GFT144-01