

5 channel Time Interval Meter

Features

- Five-channel Time-Interval Meter: One Start and four Stops
 - 13 picosecond resolution
 - < 50 picosecond's RMS jitter
 - > 100 second's range
 - 10 MHz sample rate per channel
- Common GATE input
- Input for external 10 MHz reference
- 4 GPIO signals for communication to external equipment
- Easy & quick control via "Control panel web page" (only 10 seconds to connect your PC)
- 100 /1000 Mbit/s Ethernet interface
- Compact 19", 1U with optional mounting flange



GFT2005 and laptop with embedded web page

Applications

- Time of flight mass spectrometry
- Lab / R&D Characterizations
- Fluorescent decay
- Real time, time stamping
- ATE (Automatic Test Equipment)
- Optical and magnetic disk timing
- Component Test
- Variation in Pulse Timing

Description

The GFT2505 is a very precise Time Interval Meter. It has five channels: Channel 0 is used as the "Start" time reference for channels 1-4 being "Stops" events of the Time Interval measurement. Each channel can measure the time of the rising edge of one electrical input, to 13 picosecond resolution with > 100 second range. Time Interval samples can be automatically processed to provide Mean, Max, Min and RMS/Jitter.

The instrument uses an internal 10 MHz oscillator or an external very stable 10 MHz source.

The Instrument offers 4 GPIO (4 digital bi-directional signals) under software control for communication to external equipment.

The GFT2005 is a low profile 19", 1U rack instrument with Ethernet interface.

The instrument as a built in Web server that provide an easy remote control via a standard Web Browser. "Control panel Web page" from embedded web server provide an easy method to:

- Configure settings for each channel and Control operation and status of the instrument
- View the measurements (value and graphic form)
- Save the measurements in your computer file

5 channel Time Interval Meter

Specifications

TIM channel	
Number	1 Start, 4 Stops
Time resolution	13 picoseconds
Time range	>100 seconds
Time Jitter	< 50 ps RMS for Time intervals below 1 ms
Channel Input	
Edge trigger	Rising
Input impedance	50 Ω
Input coupling	DC
Threshold	Programmable from -2.5 to +2.5 Volts
Max safe input	\pm 3.3 Volts
Gate Input	
Level	2 Volts minimum, active high
Input impedance	50 Ω
Clock Reference	
Internal	10 MHz, available as TTL output
External	10 MHz \pm 10 PPM reference, 1 Volt p-p min
Measurement	
Measurement trigger mode	Single or Repetitive (repeat count and repeat period are adjustable)
Sample per measurement	1 to 1000
Sample rate	Up to 10 MHz
Measurement type	Mean, Max, Min, RMS/jitter of samples Graphic form of samples Mean File of sample and mean measurement
GPIO	
Number of GPIO signals	4 (digital bi-directional signal)
Signal level input	2.0 V High min, 0.8 V Low max
Signal level Output	2.4 V High min, 0.6 V Low max at 24 mA
General	
Control interface	10 / 100 / 1000 Mb/s Ethernet
Software	Set of Ethernet commands Web page for Internet explorer, Chrome, Firefox
Power	< 20 W, 90-240 V / 50-60 Hz
Indicators	Power, Trigger, Busy
Connectors	Channel 0 to 4, Gate, Clock: BNC Ethernet: RJ45
Dimension / Weigh	19", 1U, 400 mm (overall dimension) / < 5 kg
Packaging	2 handles in front and rear panel

5 channel Time Interval Meter

Functional Overview

Block diagram

The GFT2005 includes the 5 following functions: Time base, Time Channel, Master Counter and Samples Memory, Mode Control and Interface controller.

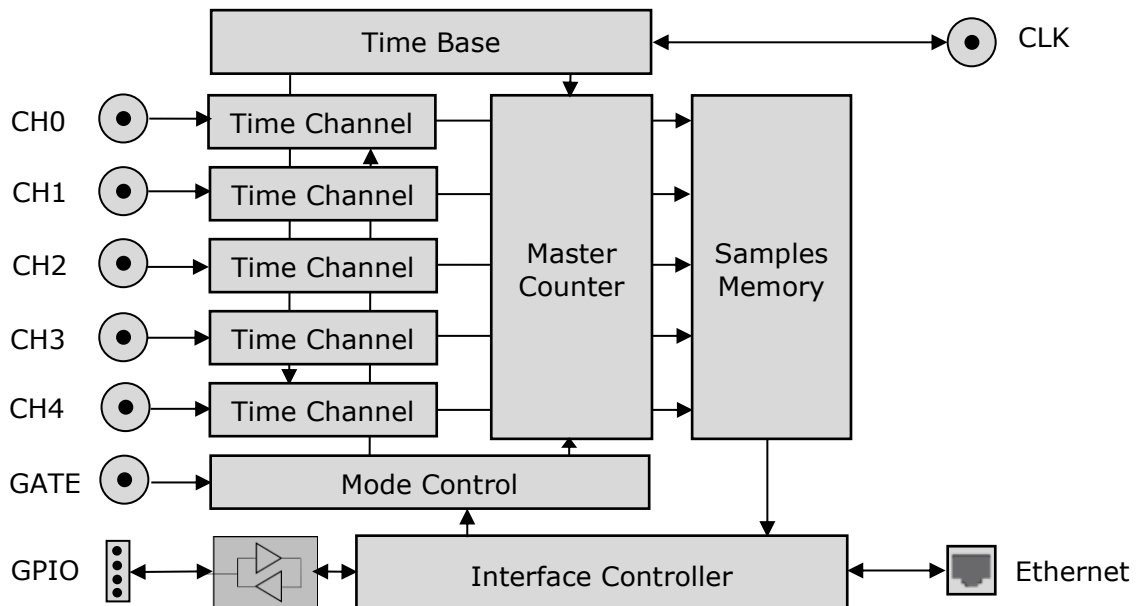

Time base

This function provides a low jitter time base locked on a 10 MHz internal reference or external reference. The internal reference is available on rear panel.

Time Channel

Each channel as an input detector which recognizes rising edge of incoming triggers. At trigger time a TDC measure "Time Channel" interval from trigger's rising edge to Time Base.

Master Counter and Sample Memory

This function is a master counter clocked from the Time base. At each trigger time the value of Master Counter is stored with the Time channel in the Sample Memory. Samples memory is able to store up to 1000 samples per channel at 10 MHz rate.

Mode control

The GFT2005 uses a relative mode controlled in this function: In this mode "Channel 0" is considered to be the Start with the "Channel 1 to 4" being Stop events of the time interval measurements. This function completes the number of samples selected then transfer samples to the Interface Controller. If the repetitive measurement is selected, the function collects a new series of sample (at the repeat period and up to the repeat count).

GATE: All channels (common command) can be set to be Enabled or Disabled from GATE input.

Interface Controller

It manages internal functions, user Ethernet interface and process Sample Memory data. Process can be for each channel: Mean, Max, Min, RMS jitter of samples. All the parameters and data can be remotely controlled via Ethernet or Internet (from embedded Web server).

GPIO: The general-purpose input output (GPIO) is intended for connecting to external equipment. It offers 4 digital bi-directional signals controlled from software commands.

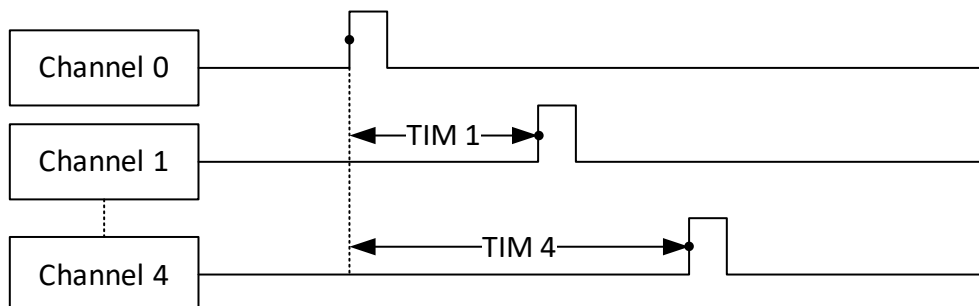

TIM (Time Interval Meter) timing principle

5 channel Time Interval Meter

Software tools

They are two ways to control the Time Interval Meter:

- **“Quick way”** via Internet and control panel web page (see below). Web page from embedded server, provides an easy method to configure settings, to control operation, to display status of the instrument, to display measurement values and to save data (samples and measurements) in "RAW" data file format for off-line analysis.

Measurement on each channel (identified by different color) can be viewed (Mean, Min, Max, Jitter) in real time and presented in graphic form (Time interval mean as function of repetitive count) in repetitive mode.

Graphic form: A Zoom of the graph is available in upper part (defined by cursors on lower part) and each data of the graph can display by clicking on it.

Repetitive mode runs like a recorder. So, it can be controlled in number of samples of measurement mean, in repetitive period and repetitive count of the measurement. All the measurements during the repetitive mode are stored in the equipment and then can be saved in your computer file.

Internet connection: The web page can be quickly opened via standard browser like internet explorer, Mozilla Firefox or Chrome (without any DLL or specific software). After connecting a cable from the GFT2005's Ethernet port to your computer network, enter the GFT2005's IP address into your PC's browser (the IP address can be identified or assigned via the web page). The browser will automatically open the control panel web page on your PC.

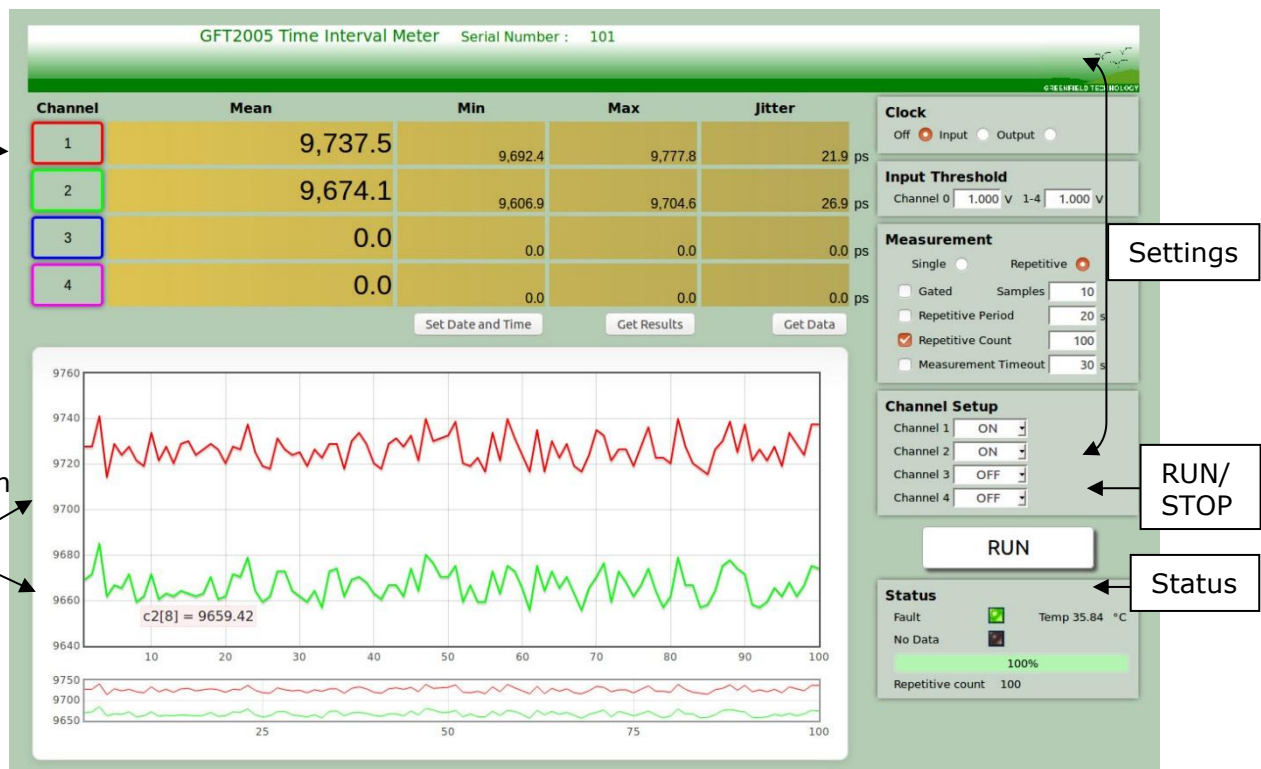

Control panel web page

- **“General remote way”** via Ethernet and LabVIEW software application or other PC software application.

GFT2005 offers a set of command to configure settings for each channel and trigger, Read the measurements, Control operation and status of the instrument

Example of use is provided in a user's manual.

5 channel Time Interval Meter

Product Interface

Front panel



Rear Panel



Interface

Front Panel			Rear Panel		
Connectors			Connectors		
1	CH0	Start Input channel 0: BNC connector	4	LAN	Ethernet Network interface: RJ45 connector
	CH1	Stop Input channel 1: BNC connector	5	GPIO	9-way D-sub connector
	CH2	Stop Input channel 2: BNC connector	6	AUX	AUX I/O: BNC connector
	CH3	Stop Input channel 3: BNC connector	7	CLOCK	10 MHz Input or Output: BNC connector
	CH4	Stop Input channel 4: BNC connector	8	Plug	AC power IEC plug (90-240 V)
2	GATE	Gate Input: BNC connector	Switch		
Indicators			9	Red Switch	Power On/Off switch
3	TRIG	Trigger			
	BUSY	Processing			
	PWR	Power ON			
	F1	T.B.D			

Ordering Information

Model	Description
GFT2005	Base version: 5 channel Time Interval Meter
-MF	Adds mounting flange

Ordering example: GFT2005-MF (model GFT2005 with mounting flange)