

## Synchronized 1 to 4 GHz Clock Drivers

### Features

- 4 synchronous high speed clock drivers  
1 to 4 GHz Clock frequency  
Programmable phase in step of 10 fs  
-4 dBm to 5 dBm output clock level.  
1 ps channel to channel jitter
- 100 MHz reference clock input
- Easy remote controlled from standard Internet browser (The user doesn't need any software)
- Compact packaging 19" W x 330 mm D x 1U H

### Applications

- High Speed Digitizer system
- Arbitrary Waveform system
- RADAR
- RF Communication
- Ultrasound
- Laser Doppler Velocimetry
- ATE (Automatic Test Equipment)

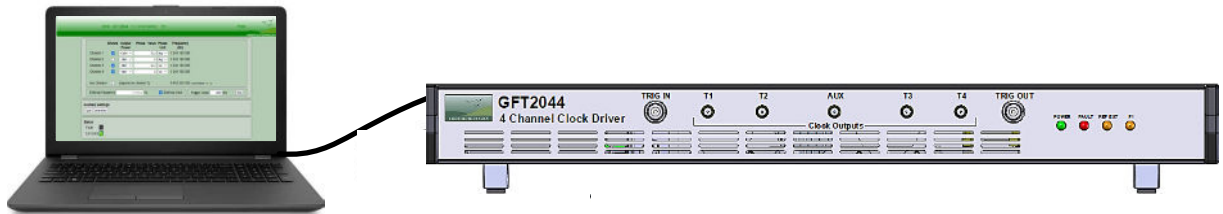

### Description

The GFT2044 is designed to provide clock distribution to synchronize up to for (4) A/D and D/A systems and arbitrary waveform generator.

Four synchronized onboard frequency synthesized generators allow to control the output clock up to 4 GHz. The synthesized generator is locked to an onboard 100 MHz reference clock and is used in conjunction with phase lock loop to control the programmed clock rate and phase value. An external 100 MHz reference can also be selected.

4 GPIO lines is available for communication to external equipment.

GFT2044 parameters may be remotely controlled over Ethernet and Internet via internal web server.

**Application example:** Typical application is to synchronize "Multichannel high speed digitizer system" with very low jitter.

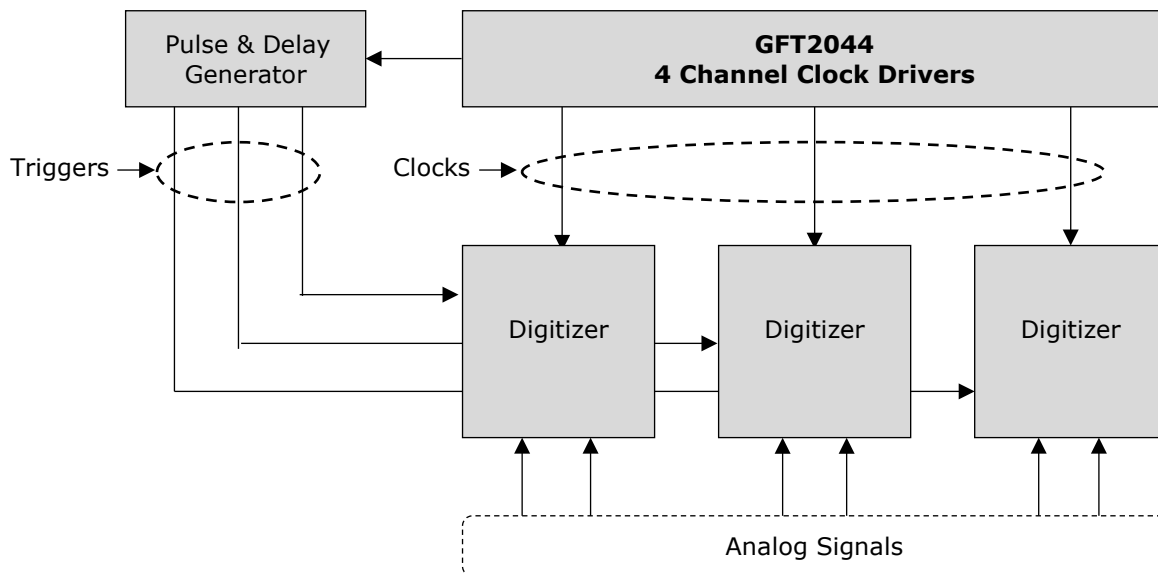

*Block diagram of the system*

# Synchronized 1 to 4 GHz Clock Drivers

## Specifications

<b>Clock channels</b>	
Number	4 synchronized
Frequency range	1 GHz to 4 GHz in step of 100 MHz (for other value ask to factory)
Phase range	0 to 360° in step of 10 fs
Channel to channel jitter	1 ps RMS
<b>Internal Time Base</b>	
Frequency	100 MHz, 100 ppb stability
Accuracy	10 <sup>-6</sup>
Phase noise @ 1KHz offset	-155 dBc/Hz
<b>Clock Channel Output</b>	
Level / Shape	-4 dBm, -1 dBm, +2 dBm et +5 dBm / Square Adjustable independently on each channel
Connector	SMA
<b>Trigger input</b>	
Trigger Level	100 mV to 5 V
Min width	20 ns (TBC)
<b>Trigger Output</b>	
Function	Input trigger synchronous with reference clock
Level	10 V, Trise < 5 ns into 50 Ω
<b>Reference Input</b>	
Level	Min -6 dBm, typical +2 dBm, max +8 dBm, threshold 0 V, internal 50 Ω
Shape	Sine or Square
Frequency	100 MHz (for other value ask to factory)
<b>Reference Output</b>	
Level	400 mV p-p
Shape	Square
Frequency	100 MHz
<b>AUX clock Output</b>	
Function	Ask to factory for specific application
<b>GPIO under software control</b>	
4 Inputs or outputs	0 or 3V level, SUB-D 9 ways connector
<b>General specifications</b>	
Interface Control	Ethernet 10/100/1000 Mb/s
Power consumption / supply	25 W / AC 88 - 264 V, 47- 63 Hz
Operating temperature	10°C to 35° C
Weight	<5 kg
Size	19" W x 330 mm D x 1U H

# Synchronized 1 to 4 GHz Clock Drivers

## Operating Information

### Block diagram of the Clock driver

The 4 channels Clock driver includes the 4 following functions: A time base with 1 to 4 splitter, four programmable Clock channels and an interface controller.

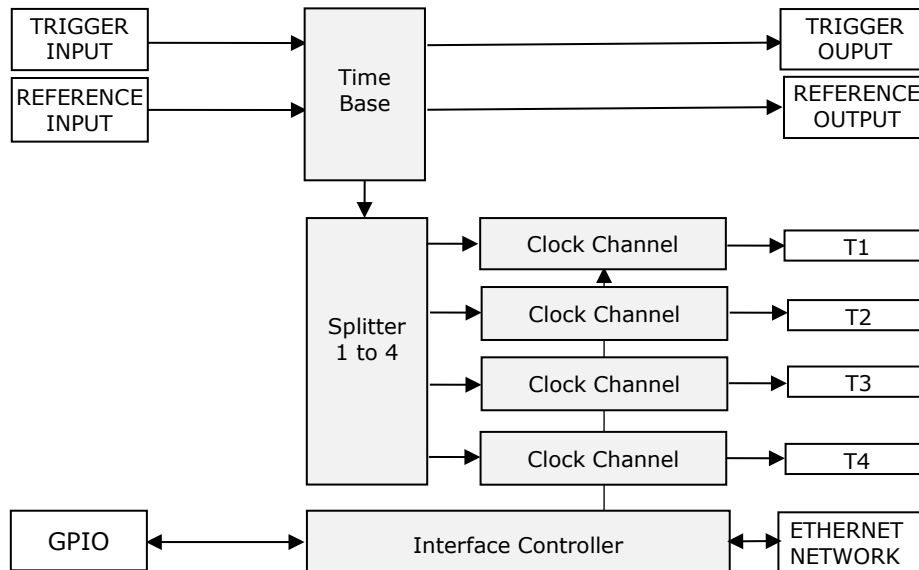

### Time base:

This function provides a 100 MHz low noise time base from an internal reference or an external 100 MHz reference. A trigger input allows to synchronize the clock channels from an external signal.

### Clock Channel:

This function locked on time base is made with programmable phase shifter and high resolution independent programmable frequency synthesizer.

A Clock Channel output amplifier provides a clock signal adjustable on each channel from -4 to +5 dBm.

### Interface Controller:

It manages internal functions and user interface. All the parameters can be remote controlled via Ethernet (10/1000 Mb/s) and Internet from internal web server.

All parameters' values are automatically saved in the unit.

**GPIO lines:** Four input or output lines under software command allow to control other devices at low frequency.

### Example of channel output mode

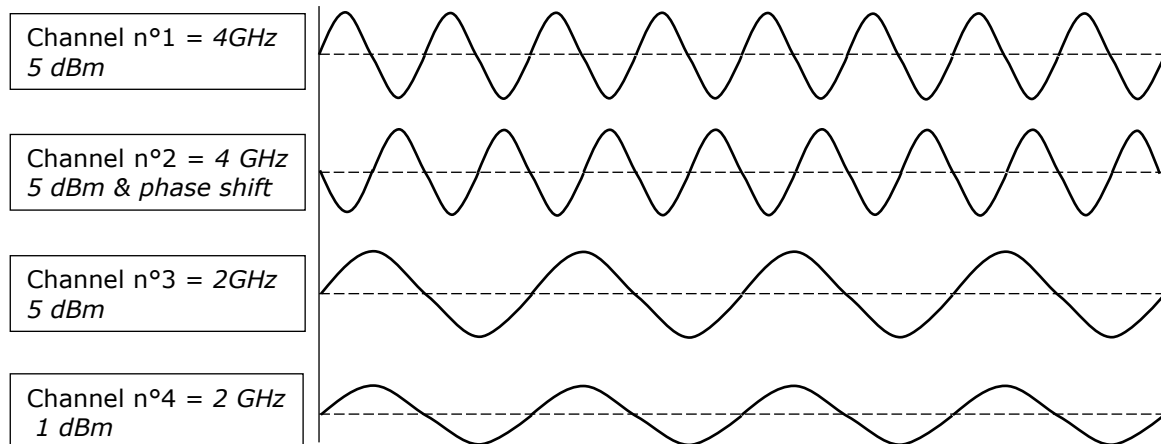

**Synchronized 1 to 4 GHz Clock Drivers**

**Example of Clock output**

**1.24416 GHz Clock into 50 Ω @ -1 dBm**

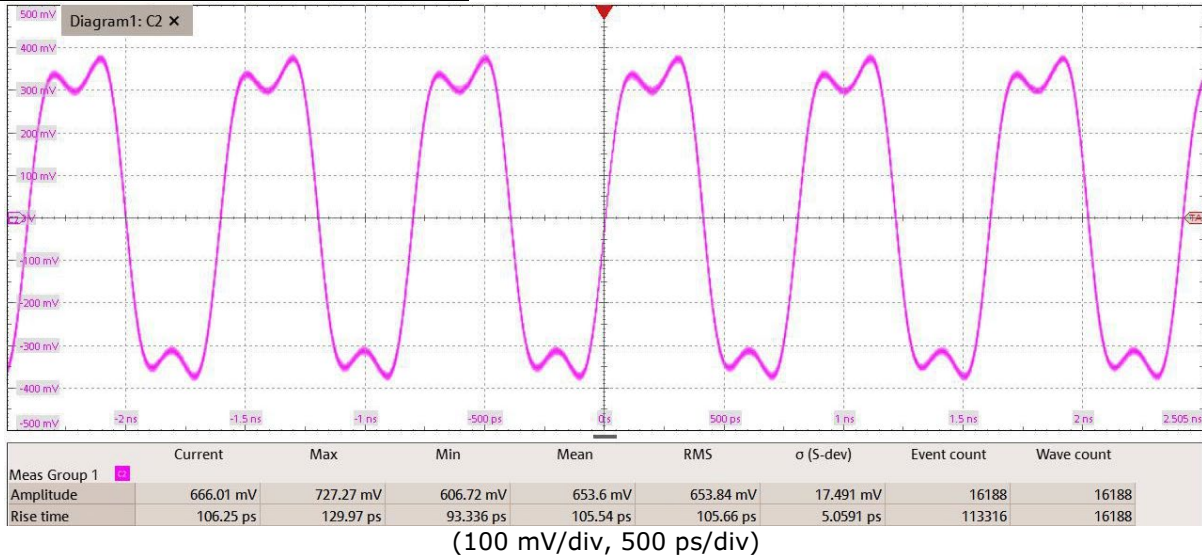

**1.24416 GHz Clock into 50 Ω @ +5 dBm**

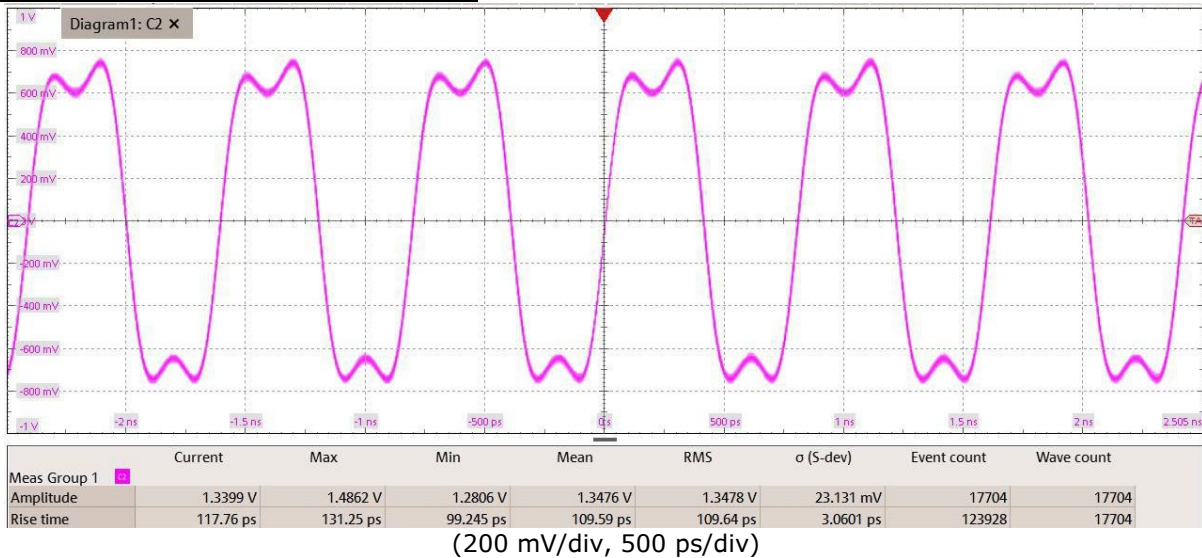

**T1 and T2 phased out of 100 ps**

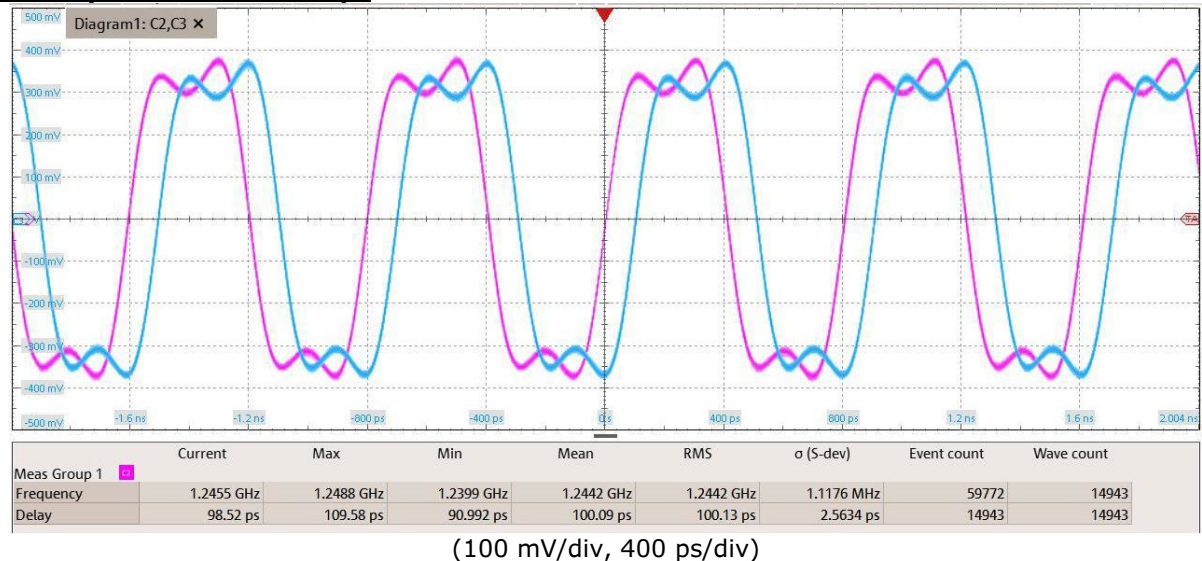

## Synchronized 1 to 4 GHz Clock Drivers

### Control and software tools

There are two ways to control the Clock Drivers.

**Easy remote way** via Internet and control panel web pages.

Web page, from embedded Web server, provides easy method to configure settings.

A Main menu allows to display and control

- On each channel
  - o Enable / disable clock
  - o Output power
  - o Phase value in degrees or ps
  - o Output frequency display
- External or Internal Reference
- Input trigger source (external or internal) and threshold
- Auxiliary settings
  - o GPIO
  - o Parameters (IP address, Net mask...)
  - o Output frequencies setup
- Status
  - o Fault (synthesizer lock, temperature too high)
  - o Switch to external reference indicator

The configuration information (all the settings) of the instrument is stored and saved in the GFT2044.

The web page can be opened via Edge, Mozilla Firefox or Chrome.

After connecting a cable from the GFT2044 Ethernet port to your computer network, enter the GFT2044 IP address into your PC's browser (the IP address can be identified in User's manual). The PC browser will automatically open the control panel web page on your PC.

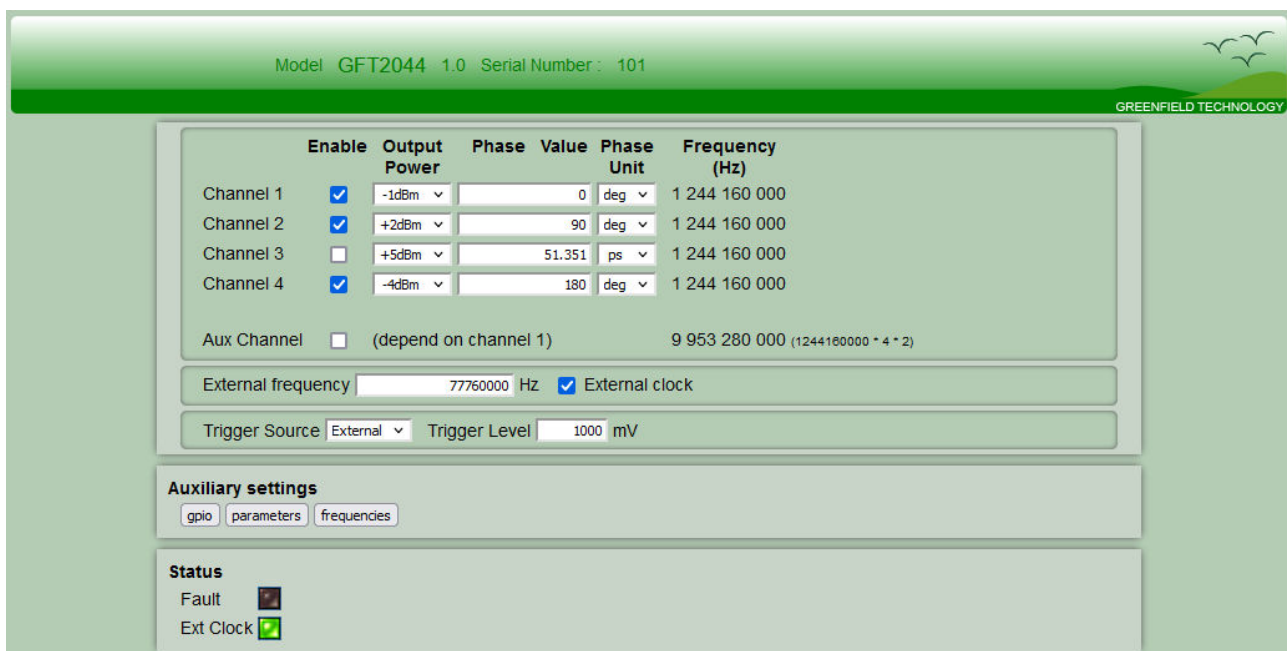

Control panel web page

**General remote way** via Ethernet and LabVIEW software application or other PC software application. GFT2044 offers a set of command to configure settings for each channel and trigger and control operation and status of the instrument.

Example of use is provided in a user's manual.

**Synchronized 1 to 4 GHz Clock Drivers**

**Product Interface**

**Front Panel**

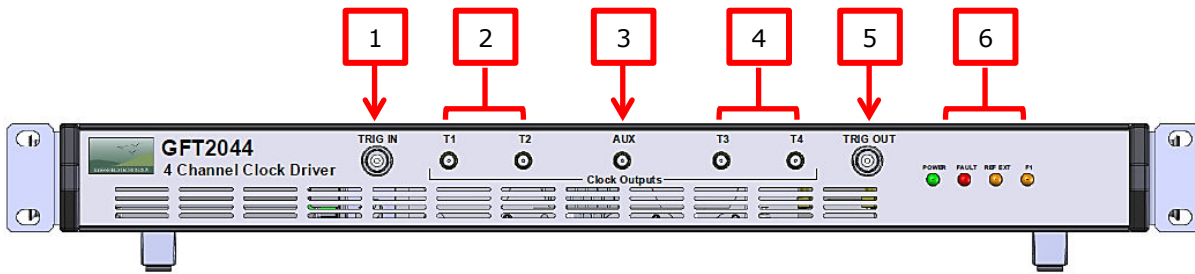

**Rear Panel**

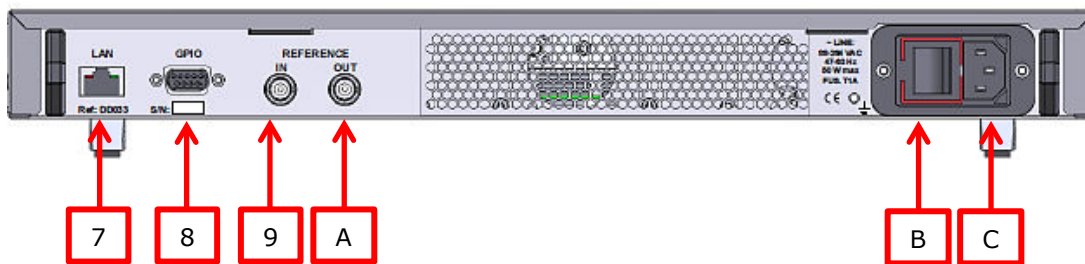

**Interface**

Front panel		Rear panel	
<b>Connectors</b>		<b>Connectors</b>	
1	Trigger input: BNC connector	7	LAN connection: RJ45 connector
2	T1 & T2 clock outputs: SMA connector	8	GPIO: subD 9 ways connector
3	Auxiliary clock output: SMA connector	9	Reference input: BNC connector
4	T3 & T4 clock outputs: SMA connector	A	Reference output: BNC connector
5	Trigger output: BNC connector	C	1 A Fuse case & AC Power plug
<b>Indicator</b>		<b>Switch</b>	
6	Power ON, Fault, Référence externe, F1	B	Red switch for power On/off

**Ordering information**

Model	Description
GFT2044	Synchronized 1 to 4 GHz Clock Drivers

Ordering example: GFT2044: Synchronized 1 to 4 GHz Clock Drivers