

GFT7513

13 GHz Low Noise Synthesizer

KEY FEATURES

- 100 KHz – 13 GHz Frequency range
- 0.0001 Hz Frequency step
- -140 dBc/Hz Phase noise @ 1 GHz center, 20 KHz offset
- 3.5 μ s Frequency switching time (200 MHz VCO step)
- USB or RS-232 interface for remote control (CP2102 USB to COM bridge)
- +12 Vdc Power Supply (AC/DC adaptor included)
- Compact packaging: 105 mm W x 256 mm D x 27 mm H



APPLICATIONS

- Local Oscillator for receiver
- Signal simulation (Radar, UWB, Telecom)
- R&D low noise signal source
- Test and measurement
- Manufacturing testing
- Service and maintenance
- Test on high speed circuits
- Automatic Test Equipment

DESCRIPTION

The GFT7513 is a low noise and fast-switching Frequency Synthesizer covering a frequency range from 100 KHz to 13 GHz; The Synthesizer provides a 0.1 mHz frequency resolution, and a wide and accurately leveled output power range.

The GFT7513 is well suited for application in Local Oscillator for receivers because it has specific electronic design to provide very low phase noise and none subharmonics.

The GFT7513 operates with high stability internal reference and can be phase-locked to any external reference from 1 MHz to 250 MHz with 1 MHz step.

The generator is a compact packaging with only 27 mm in height and 1.8 Kg in weight.

The module has a USB and RS-232 interface for remote control. It is supplied with windows software application which includes a front panel graphical interface.

GFT7513

13 GHz Low Noise Synthesizer

SPECIFICATIONS

The specifications in the following pages describe the warranted performance of the signal generator for 23 ± 10 °C after a 30 minute warm-up period.

Parameter	Conditions	Value		Unit
		Min	Max	
RF Output & General Characteristics				
HB output frequency range		100	13000	MHz
LB output frequency range		0.1	250	MHz
Min frequency step	All frequency		$1 \cdot 10^{-4}$	Hz
Frequency switching time	200 MHz VCO step		3.5	μ s
	1 GHz VCO step		30	μ s
	6 GHz VCO step		120	μ s
HB output power	RF out, 0.1 to 13 GHz	-14	+15	dBm
HB output power step	RF out, 0.1 to 13 GHz	0.5		dBm
LB output power	Fixed level	9	11	dBm
Output power flatness	RF out, 0.1 to 12GHz		6	dBpp
Nominal output impedance			50	Ω
Output VSWR			2.1	
Spectral Purity & Phase Noise Characteristics				
Phase noise normalized to 1 GHz center frequency, Pout = +17 dBm, typ.	Fout = 1 GHz, @ offset			
	100 Hz		-110	dBc/Hz
	1 kHz		-129	dBc/Hz
	10 kHz		-139	dBc/Hz
	100 kHz		-141	dBc/Hz
	1 MHz		-141	dBc/Hz
	10 MHz		-143	dBc/Hz
	30 MHz		-151	dBc/Hz
Spurious suppression (except harmonics), all frequency range	Worst		-60	dBc
	type		-80	dBc
Harmonic suppression	6 GHz to 13 GHz, +10 dBm		-23	dBc
	< 6 GHz, 2-nd harmonics	-45	-30	dBc
	< 6 GHz, 3-nd harmonics		-10	dBc
Internal Reference Frequency Characteristics				
Temperature stability	0 to +50°C (base option)		+/-100	ppb
Digital frequency adjustment		+/-0.5	+/- 1	ppm
Aging 1-st year			+/-50	ppb
Allan variance	At 1 s		20×10^{-12}	
External Frequency Reference Characteristics				
Frequency	1 MHz step	1	250	MHz
Operating temp. range		-40	+65	°C
Input level of external reference signal		-10	+10	dBm
REF output	10 or 100 MHz, 50 Ω load		10+/-3	dBm
External Trigger				
Voltage range		0	3	V
DC offset			1.5	V
Hysteresis			50	mV
Power Supply				
+12 V supply voltage current			1.9	A
AC/DC module voltage	Module is delivered with GFT7513	90	240	V
Dimensions & Weight				
Length	Excluding SMA connectors		256	mm
Width			105	mm
Height			27	mm
Weight			1.8	kg

Dynamic performance

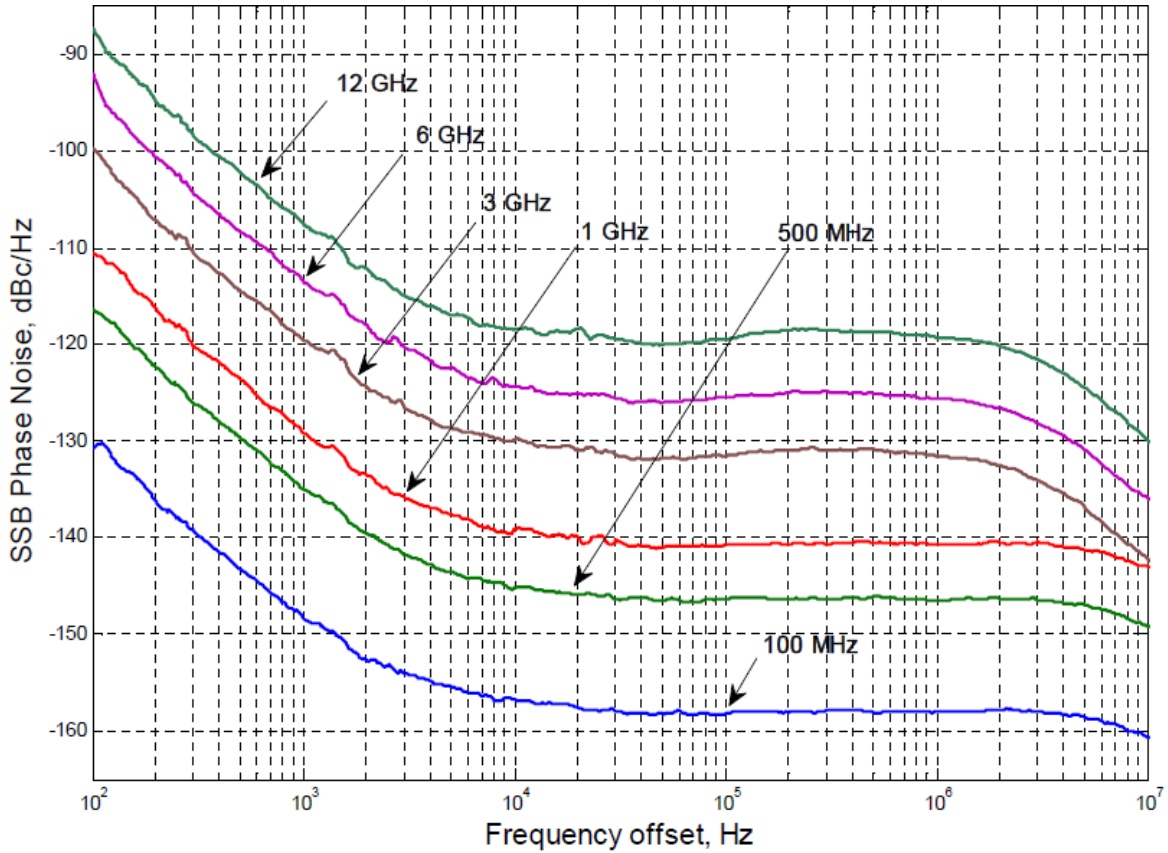

Phase noise vs frequency offset, +10 dBm, internal reference

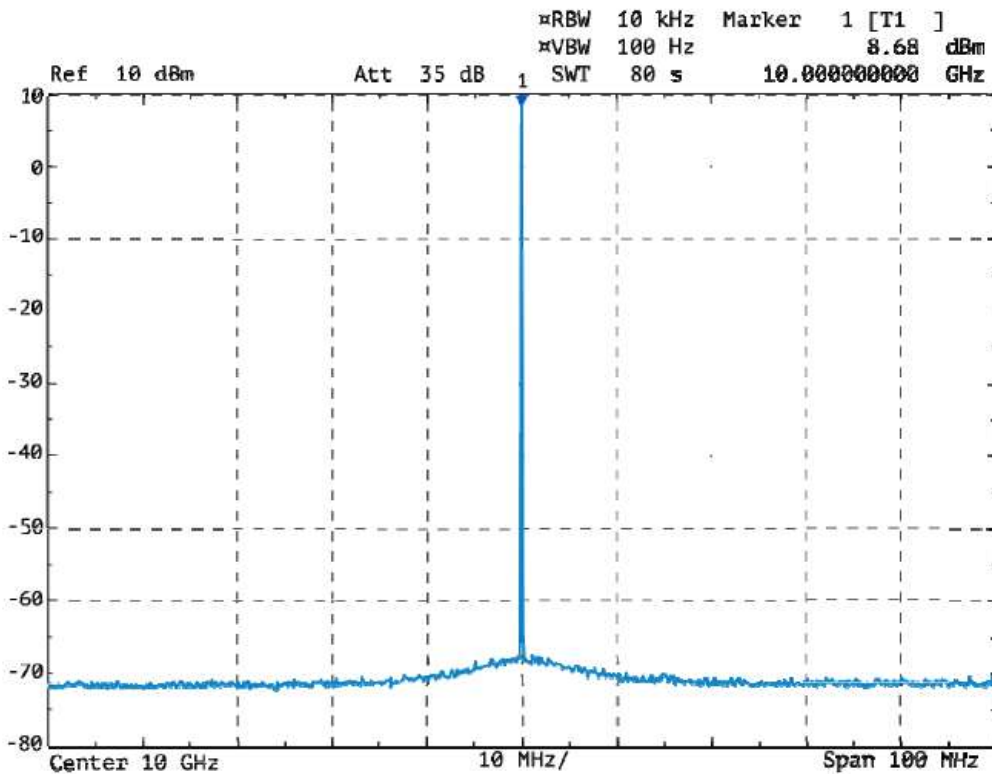

GFT7513

13 GHz Low Noise Synthesizer

SFDR at 10 GHz, +10 dBm, internal reference

FUNCTIONAL OVERVIEW

Block diagram

GFT7513 synthesizer consists of two blocks:

- Control PCB based on the microcontroller
- RF-module based on three PLL loops.

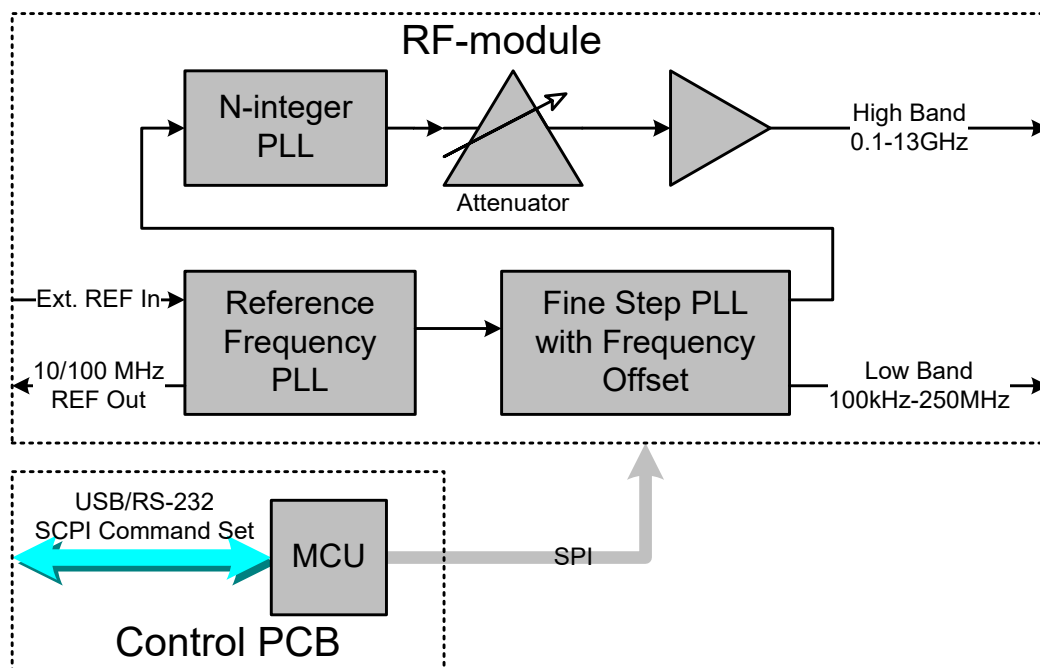

Block diagram of GFT7513 Synthesizer

RF module

First PLL with very narrow band is used to clear external reference and to produce high quality 100 MHz internal signal.

Second PLL with frequency offset is used to produce fine frequency resolution signal. This signal is fed to third N-integer PLL following by variable attenuator and amplifier.

Low band signal is fed directly from DDS which is used in the second PLL.

Control PCB

The remote control of the synthesizer is based on the SCPI (Standard Commands for Programmable Instruments) protocol. It is implemented via RS-232 and USB interface located on rear panel of the instrument.

GFT7513

13 GHz Low Noise Synthesizer

SOFTWARE TOOLS

The module has a USB and RS-232 interface for remote control. It is supplied with windows software application which includes a front panel graphical interface. This software application can be used to control and explore the capabilities of the 13 GHz low noise synthesizer.

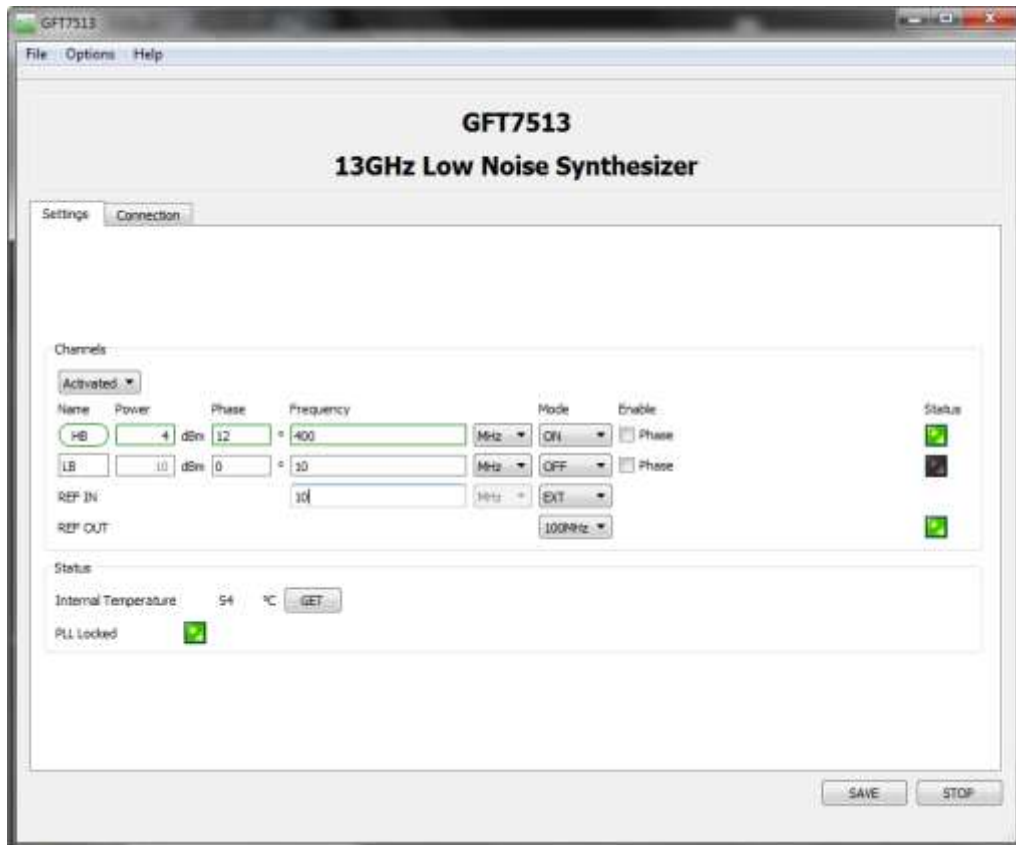

Only one of the two frequency channels (High Band and Low Band channel) can be selected at a time. The selection is done by the dedicated mode combo box (ON/OFF).

Each channel owns the same set of parameters: power, phase and frequency.

- ✓ The HB frequency can be set from 100 MHz to 13 GHz and the LB frequency from 100 kHz to 250 MHz.
- ✓ It has to be noticed that only the HB power is configurable – specified in dBm. LB power is fixed to 10 dBm.
- ✓ To enable phase adjustment the user has to check the “Enable Phase” check box. Phase has to be specified in degrees.

Once the selected channel configured, to enable the RF output the user has to activate the global channel output setting. Once done, the user can switch from one channel to the other by using the dedicated mode combo box. When a channel is activated its LED status is green, A sweep mode is also available. It can be displayed by turning on/off the “Sweep mode” setting located in the “Options” tab. Once displayed, the user can choose the used sweep method by selecting it via the sweep method combo box: Center/Span or Start/Stop.

At least, a status report is available. By pressing the “Get” button the GUI will display PLL status and device internal temperature.

A “Save” button is available on the GUI. Each time a GUI setting is modified, the user can save the current configuration of the device (including the global channel output state). This configuration will be call back during the next power up of the device by the device itself, without using the GUI. This feature can be interesting in a stand-alone use.

GFT7513

13 GHz Low Noise Synthesizer

FRONT and REAR PANELS



Front Panel

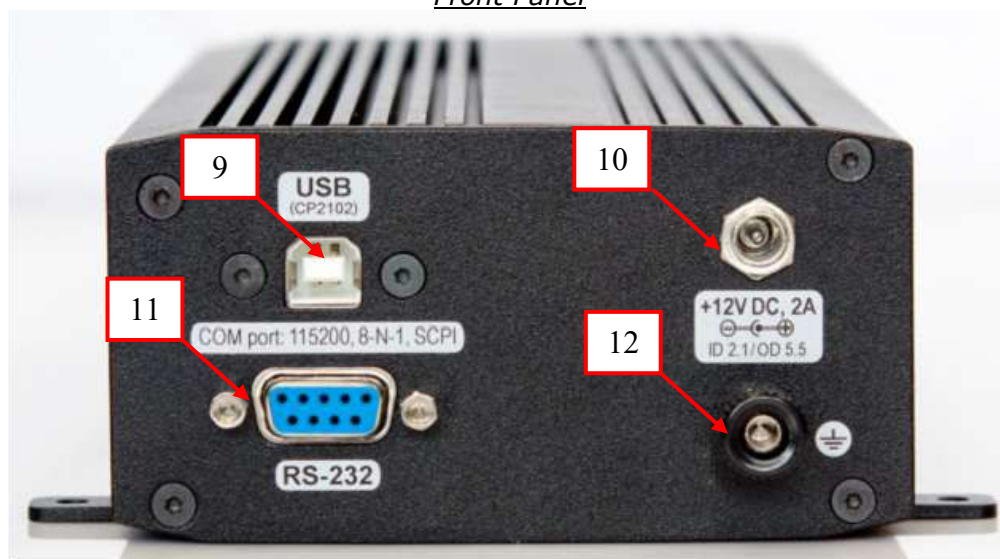

Rear Panel

Connector, Switch, Indicator

Front Panel	Rear Panel
<ul style="list-style-type: none"> Indicators 	<ul style="list-style-type: none"> Connectors
(3) High Band Power ON (red)	(9) USB connection: USB type B
(5) Low band Power ON (red)	(10) +12V DC power plug
<ul style="list-style-type: none"> Connectors 	(11) RS232 connection: D-SUB 9 way
(2) RF High band out: SMA connector	(12) GROUND
(4) RF Low band out: SMA connector	
(6) Trigger input: BNC connector	
(7) Reference out: BNC connector	
(8) Reference In: BNC connector	
<ul style="list-style-type: none"> Switch 	
(1) Power On/Off	